



PVL Series: 68, 124, 136 and 144 Watt

Field Applied PV Laminate Installation Guide for Steel Roof Systems

- ✓ For Top Terminated Laminates (with Quick Connects (MC[®]) or Junction Boxes)
- ✓ For Bottom Terminated Laminates (with Junction Boxes)
- ✓ Includes Solutions for Mid-Roof Connection of Laminates Bonded to the Same Pan
- ✓ Includes PVL Checklist and Final Report for Installers
- ✓ Appendix #1 - Wiring PVL Modules with “Quick Connect (MC[®])” Terminals

TABLE OF CONTENTS

| | |
|---|-----------|
| SECTION 1 | 3 |
| 1.1. Introduction | 3 |
| 1.2. Safety Warnings | 4 |
| 1.3. General Metal Roofing Installation Notes | 5 |
| 1.4. Field Applied PV Laminate (PVL) Specifications | 6 |
| 1.5. Application of the Field Applied PV Laminate | 9 |
| SECTION 2 | 10 |
| 2.1. Detailed PVL Application Instructions – With Top Mounted J-Box Laminate Installation | 10 |
| PVL Modules supplied with Factory “Quick Connect” Wires and Terminals | 11 |
| Top Mounted J-Box Installation | 12 |
| 2.2. Detailed PVL Application Instructions - With Bottom Mounted Junction Box | 16 |
| SECTION 3 | 24 |
| 3.1 PVL with Quick Connects (MC [®]) | 24 |
| SECTION 4 | 26 |
| 4.1. General Wiring Instructions for PVL Modules | 26 |
| 4.2. Four Termination (Wiring) Options for PVL Modules on Steel Roofs | 28 |
| 4.3. Maintenance | 39 |
| SECTION 5 | 40 |
| 5.1. Addendum #1: Wiring UNI-SOLAR PVL Modules with Quick Connect (MC [®]) Terminals | 40 |
| 5.2. PVL Installation Check List and Final Report | 43 |
| Contacts | 47 |

Field Applied PV Laminates PVL-68, PVL-124, PVL-136, PVL-144

INSTALLATION GUIDE

SECTION 1

1.1. Introduction

United Solar Ovonic LLC, the leader in thin-film amorphous-silicon photovoltaics (PV) offers an innovative line of PV modules. Unlike other photovoltaic technologies that use glass to protect their modules, *UNI-SOLAR*[®] modules are flexible, lightweight and architecturally attractive. These rooftop solar systems, where *UNI-SOLAR* photovoltaic modules are bonded to conventional steel pans, emulate conventional roofing solutions in design, construction, function and installation.

UNI-SOLAR Field Applied PV laminates (PVL) are designed to provide many years of reliable roofing protection and independent electric power. They will perform at their maximum with the proper power system design, installation, use and maintenance. This manual is designed to assist product owners, roofers, and electricians in the proper use and installation of this product.

The UNI-SOLAR PVL Series modules are lightweight and flexible. These laminates are field applied (i.e. cold bonded) to Zn-Al coated steel pans (Galvalume[®], Zinalume[®], or equivalent) using a “peel and apply” application process. Authorized installers do the application of these laminates to steel pans. Installation of the pans (with laminates) requires only a few, but important, modifications of the conventional installation procedures (location of fasteners, clip modification, Z-closure height). Roofers should be thoroughly familiar with the standard procedures prior to installation. Only qualified, licensed electricians should undertake wiring of the panels to the building’s electrical system.

UNI-SOLAR PV laminates are designed for use with other specialized equipment, including DC combiner boxes, charge controllers, DC/AC inverters, and ground fault protection and interruption equipment. System design and component selections must comply with the National Electric Code (NEC) and all state and local codes.

DISCLAIMER OF LIABILITY

The information contained in this manual is based on United Solar Ovonic LLC’s knowledge and experience, but such information and suggestions do not constitute a warranty expressed or implied. The methods of installation, use and maintenance of steel panels are beyond the control of United Solar Ovonic LLC. United Solar Ovonic LLC assumes no responsibility and expressly disclaims liability for any loss, damage or expense associated with the use, installation or operation of the metal roofing system. Any liability of United Solar Ovonic LLC is strictly limited to the United Solar Ovonic LLC Limited Warranty. United Solar Ovonic LLC reserves the right to make changes to product specifications or to this manual without notice.

1.2. Safety Warnings

- The *UNI-SOLAR* Field Applied PV laminates produce DC electricity when exposed to the sun or other light sources. The laminates produce voltage even when not connected to an electrical circuit or load. Observe all electrical safety precautions to avoid shock.
- Do not attempt to concentrate sunlight on the laminates for increased output. Doing so may cause damage and will void the warranty.

DANGER!! 

The *UNI-SOLAR* PV laminates contain live electrical components enclosed and protected within. Do not cut or trim the photovoltaic laminate (bonded to the metal pan) in any way. Do not drive screws into any part of the photovoltaic laminate except at designated areas near the junction box or terminal covers. Doing so can cause electric shock, may result in fire and will void the warranty.

Roofing Contractor and Licensed Electrician's Responsibilities:

- Only licensed roofers should install *UNI-SOLAR* PVL products.
- All installation and safety instructions should be understood before attempting to install, wire, operate and maintain the laminates.
- Do not use the terminal housing wires to hold or transport the laminate
- *UNI-SOLAR* PV laminates are slippery, especially when wet. Use extreme caution and proper fall protection equipment when working on or near the panels as required if working at heights near the edge of a roof or on a steep roof.
- Do not place equipment on solar laminates.
- Contact appropriate local authorities prior to installation to determine if permits and inspections are required for your particular area.
- Installation shall be in accordance with NFPA 70:National Electrical Code and CSA 22.1, Safety Standard for Electrical Installations, Canadian Electrical Code, Part 1
- Observe safe electrical practices at all times. Use insulated tools and proper personal protective equipment when wiring solar PV laminates.
- Cover solar panels with an opaque material (i.e. cardboard) before making wiring connections to reduce the risk of electric shock or sparks.

- Observe proper polarity when connecting the solar PV laminates into an electrical circuit (see section on wiring). Reverse connection will damage the PV laminates, may result in fire and will void the warranty.
- Avoid dropping any sharp objects on solar PV laminates.
- Do not disconnect Quick Connect cables under load as an arc flash can occur.

1.3. General Metal Roofing Installation Notes

- *UNI-SOLAR* field applied PV laminates are bonded to metal roofing pans following procedures detailed in this manual. The laminates are to be installed on a new roof while the pans are still on the ground. Any existing roof has to be qualified by *UNI-SOLAR* Engineering before the warranty can be validated.
- Laminates are to be bonded to Zinc-Aluminum coated steel pans. Other Substrates must be approved by United Solar Ovonic LLC or the warranty will be voided.
- *UNI-SOLAR* field applied PV laminates are bonded to steel pans that are at least 16 inches (42 cm) in width and have a flat profile. Laminates cannot be bonded to pans with decorative stippling, pencil beads or stiffening ribs. Additionally, metal roofing pans with striations may not qualify for laminate bonding.
- *UNI-SOLAR* field applied PV laminates are bonded to steel pans and secured in place the same as traditional metal roofing panels using anchor panel clips and fasteners (available from the metal roofing panel manufacturer).
- *UNI-SOLAR* field applied PV laminates are wired into the solar energy system from the top of each module. This area has spaces where the laminate can be penetrated by roofing screws that may be used to hold on a Z-closure or other metal trim at the peak of the roof. Installers must be aware of these “penetration areas” at the top of the laminate so that they can properly prepare and plan for exactly where the laminates will be located on the pan so as to align the ridge cap, ridge trim and metal roofing fasteners to the penetration areas on the PV laminate.
- The PVL laminates come in a variety of lengths. To fit an individual roof length, the appropriate PVL laminate is bonded to a steel pan that fits the length of the roof.
- Water tightness is a function of the metal erector. For best results, a minimum layer of 30# felt paper should be applied between a structural steel pan and a deck substructure. Felt paper is unnecessary if the steel pans are mounted on purlins.

- Roofing components such as polyethylene closures or metal top closures shall not be attached unless the proper sealant is placed under or around those closures. Sealant shall be field applied on dry clean surfaces.
- Roof clips, as required, shall allow for thermal movement and should be installed at each panel joint. To control thermal expansion in one direction, the panel will be fastened to the substructure below at the top of the panel only. This applies when the module junction box (j-box) is mounted on top of the pan.
- Some field cutting and fitting of panels and flashing is to be expected by the erector and minor field corrections are a part of normal erection work.
- Additional help can be found in the steel pans supplier's installation instructions.

1.4. Field Applied PV Laminate (PVL) Specifications

| Physical Specification: | Laminate Length | Laminate Width | Laminate Thickness | Weight |
|-------------------------|----------------------------|----------------------|--------------------|----------|
| PVL-68 | 9 ft. 4 $\frac{1}{8}$ in. | 15 $\frac{1}{2}$ in. | 0.16 in. | 9 lb. |
| PVL-124 | 16 ft. 5 $\frac{1}{8}$ in. | 15 $\frac{1}{2}$ in. | 0.16 in. | 15.5 lb. |
| PVL-136 | 18 ft. | 15 $\frac{1}{2}$ in. | 0.16 in. | 17 lb. |
| PVL-144 | 18 ft. | 15 $\frac{1}{2}$ in. | 0.16 in. | 17 lb. |

| Electrical Specification: | PVL-68 | PVL-124 | PVL-136 | PVL-144 | Units |
|--|--------|---------|---------|---------|-------|
| Rated Power P_{max} | 68 | 124* | 136 | 144 | Watts |
| Nominal Operating Voltage | 12 | 24 | 24 | 24 | Volts |
| Operating Voltage (Volts) V_{mp} | 16.5 | 30.0 | 33.0 | 33.0 | Volts |
| Operating Current (Amps) I_{mp} | 4.13 | 4.13 | 4.13 | 4.36 | Amps |
| Open-Circuit Voltage (Volts) V_{oc} | 23.1 | 42.0 | 46.2 | 46.2 | Volts |
| Short-Circuit Current (Amps) I_{sc} | 5.1 | 5.1 | 5.1 | 5.3 | Amps |
| Series Fuse Rating (Amps) | 10 | 10 | 10 | 10 | Amps |
| Min. Blocking Diode | 10 | 10 | 10 | 10 | Amps |

Temperature Coefficients (at AM 1.5, 1000 W/m² irradiance):

Temperature Coefficient (TC) of I_{sc}: 0.001/°K (0.10%/°C)
Temperature Coefficient (TC) of V_{oc}: -0.0038/°K (-0.38%/°C)
Temperature Coefficient (TC) of P_{max}: -0.0021/°K (-0.21%/°C)
Temperature Coefficient (TC) of I_{mp}: 0.001/°K (0.10%/°C)
Temperature Coefficient (TC) of V_{mp}: -0.0031/°K (-0.31%/°C)
 $y = y_{reference} \cdot [1 + TC \cdot (T - T_{reference})]$

NOTES:

- During the first 8-10 weeks of operation, electrical output exceeds specified ratings. Power output may be higher by 15%, operating voltage may be higher by 11% and operating current may be higher by 4%.
- Electrical specifications tolerance for P_{max} is +/-5% and for other parameters is +/-10%. Electrical specifications are based on measurements performed at standard test conditions of 1000 W/m² irradiance, air mass 1.5, and cell temperature of 25°C (per ASTM E892) after long-term stabilization. Actual performance may vary up to 10% from rated power due to low temperature operation, spectral and other related effects.
- Under normal conditions a photovoltaic module may experience conditions that produce more current than reported at Standard Test Conditions. Accordingly, the values of I_{sc} marked on UL Listed modules should be multiplied by a factor of 1.25 when determining conductor capacities, fuse sizes and size of controls connected to the module output. Refer to Section 690-8 of the National Electric Code for an additional multiplying factor of 1.25 which may be applicable.
- Maximum system open-circuit voltage not to exceed 600 VDC.
- Specifications subject to change without notice.

Roof Specification

The PVL module can only be installed on sloped, UL-listed metal roofing systems where the roof slope is between 3.5° degrees and 60° degrees. The PVL module can also be applied to barrel-shaped, UL-listed metal roofing systems that have a minimum radius of 50 ft. In all cases, the *UNI-SOLAR* PV laminates cannot be applied to roofs that will experience temperatures in excess of 85° C (185° F).

The bonding of laminates in the field must be accomplished when the laminates and ambient temperatures are between 10° C (50° F) and 38° C (100° F). If the laminates are too cold, the adhesive will not cure as quickly. If the laminates are too hot, the removable film over the adhesive will become difficult to remove as you are bonding the laminate to the metal roofing pan.

Approved Substrates

Aluminum-Zinc coated steel, AZ50 minimum per ASTM A792\792M (Galvalume[®], Zinalume[®], or equivalent) with or without PVDF (Kynar 500[®], Hylar 5000[®], Valspar Fluropon[®] or Equivalent)

PVL Models and Part Numbers:

| Description | Model | Part Number |
|--|--------------|-------------|
| 68 W, Bottom Termination, Std. J-Box with 4" wires | PVL68B S/S | M535223 |
| 68 W, Top termination, Terminal Housing with Quick Connects | PVL68T QC/S | M535128 |
| 124 W, Top termination, Terminal Housing with Quick Connects | PVL124T QC/S | M537128 |
| 136 W, Bottom Termination, Std. J-Box with 4" wires | PVL136B S/S | M538223 |
| 136 W, Top termination, Terminal Housing with Quick Connects | PVL136T QC/S | M538128 |
| 144 W, Top termination, Terminal Housing with Quick Connects | PVL144T QC/S | M638128 |

NOTE: If you must penetrate the laminate with a screw for any reason (e.g. to install a "Z-closure" into the roofing system), installers can use the screw penetration template included with their PVL shipment. A picture of the template is shown below.

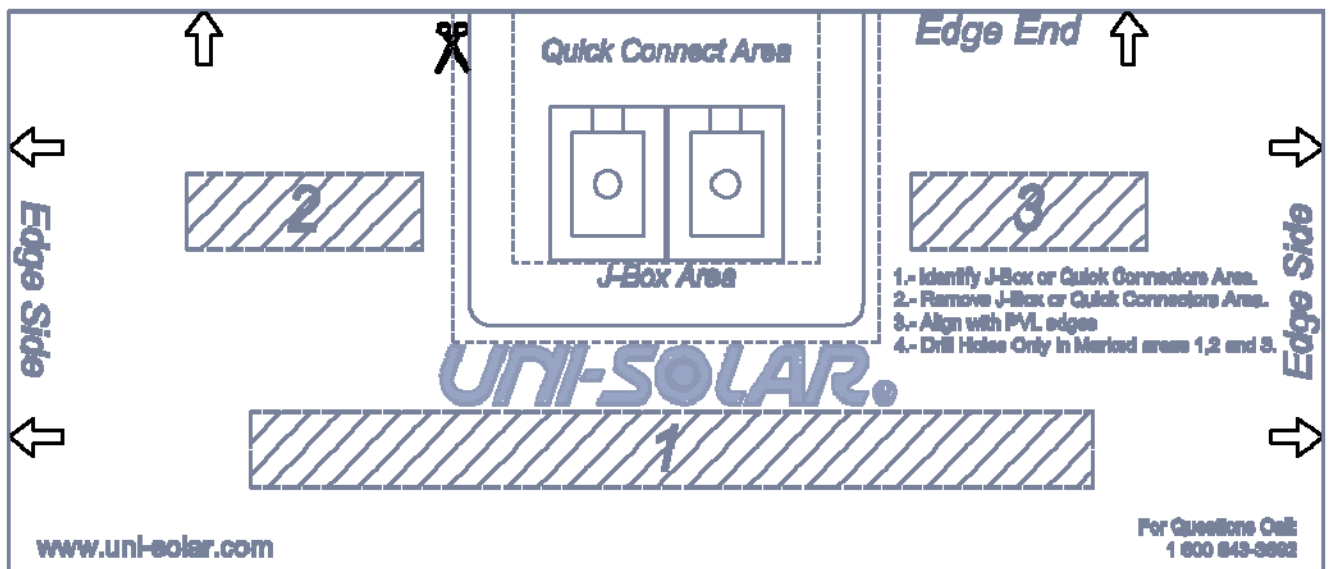

1.5. Application of the Field Applied PV Laminate

Transportation and Handling of the PVL Product

- *UNI-SOLAR* PVL modules are shipped coiled in a 4'×4'×17" transport boxes.
- *UNI-SOLAR* field applied PV laminates are to be stored in ambient temperatures of 15°C to 30°C (50°F to 85°F)
- *UNI-SOLAR* PV laminates must be handled so as to not crease or bend the solar cells. Cells are interconnected with copper bus bars and these bus bars must not be stretched beyond their tolerances by coiling the laminate any tighter than **20 inches** in diameter.
- Avoid standing on the PV laminates whenever possible. If unavoidable, wear clean, soft-soled shoes and walk in the center of the panel. **CAUTION!!** Laminates are especially slippery when wet.

Supplied Equipment and Required Tools

- All boxes of PV Laminates that are manufactured with the "quick connect" terminations contain the PV laminates, cable strain relief (two cable mounts and two cable ties per laminate) and a template for indicating proper screw penetration areas (see View 15).
- All boxes of PV Laminates that are manufactured to accept the standard J-box option contain the PV laminates, and one j-box, one wiring terminal block, two jumpers, two screws (#12-1, Self Drilling, 5/16th hex washer head with sealing washer), four Phillips head J-Box lid screws and one j-box lid for each of the contained PVL laminates. The caulk required for bonding the j-boxes to the laminates and a template for indicating proper screw penetration areas are also included.
- The PVL product installation will require a roller called a J-roller because of its shape. Other rollers can be used but we recommend that the roller itself be made of a soft rubber material, ergonomically shaped for effective pressing and the handle of the roller attached to only one side of the roller axle. This will allow you to use the roller up against the edge of the standing seam and not scratch the paint.
- Cleaning solutions will need to be acquired for the steel pans. If the pans are new, use Isopropyl Alcohol. The alcohol should be diluted to 90% alcohol / 10% water to improve cleaning. If the steel pans have been stored outside or have been installed on the roof for more than a few weeks, another cleaning solvent made up of Trisodium phosphate, laundry detergent and water can be put through a power washer prior to cleaning with the alcohol solution. The recipe for this cleaning solution is detailed later in this manual.
- Other tools required include a ruler, a marker (e.g. a carpenter's pencil), cleaning towels and a caulk gun. A flat, rigid working surface will be required for the laminate bonding (rolling) procedure. The laminate should be applied before the steel pan is installed on the roof.

SECTION 2

2.1. Detailed PVL Application Instructions – With Top Mounted J-Box

Laminate Installation

1. Remove any protective film from the face of the steel pan. Clean the steel pan with ISOPROPYL ALCOHOL (90% Alcohol - 10% Water) where the double stick and the laminate will be placed. If the pan is very dirty (material has been stored outside), the pan should be washed using a low-pressure water spray (i.e. garden hose) or power washer (ex. 1600 PSI) and a cleaning solution [$\frac{1}{4}$ Cup Trisodium Phosphate, $\frac{1}{2}$ cup liquid detergent (optional) and 5 gallons water: then rinsed before cleaning with alcohol solution.
2. PVL should be bonded while still on the ground on a flat and rigid surface with temperature between 10°C and 38°C (50°F and 100°F). Unroll and align the laminate and double stick assembly in the center of the steel pan. The laminate assembly should be positioned ~25mm (1 inch) from the end of the steel panel (see View #1)

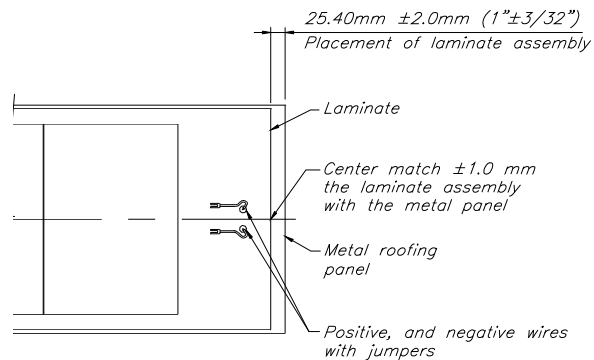

View 1

3. Lift up the laminate and double stick assembly about 300 mm (12") off of the steel pan, peel the release paper off of the double stick material approximately 150 mm (6") off the metal and fold it under. Ensure that the laminate is centered on the metal panel, and that the laminate assembly does not move on the metal

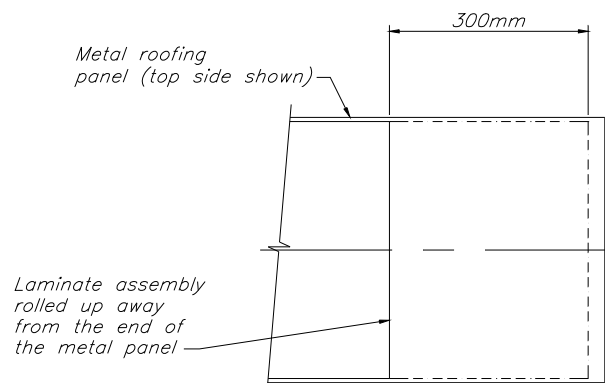

View 2

panel during the process (see View 2). This is critical, as **the laminate's position will be fixed after the first six inches is bonded to the steel pan.**

4. Stick the peeled end of the laminate assembly onto the steel pan. Roll up the rest of the laminate assembly up to the stuck portion of the laminate. After the laminate assembly is rolled up on the steel pan, one person should peel the release paper from the bottom of the laminate assembly as another person unrolls the laminate onto the steel pan. Stick the remaining laminate against the pan, making sure the laminate is aligned properly on the steel pan.
5. After the laminate has been applied completely to the steel pan, use a roller to press the center of the laminate against the steel pan (See View 3). Then use a roller to press the laminate onto the steel pan, starting from the center of the laminate, and rolling out to the edges of the laminate (See View 4).

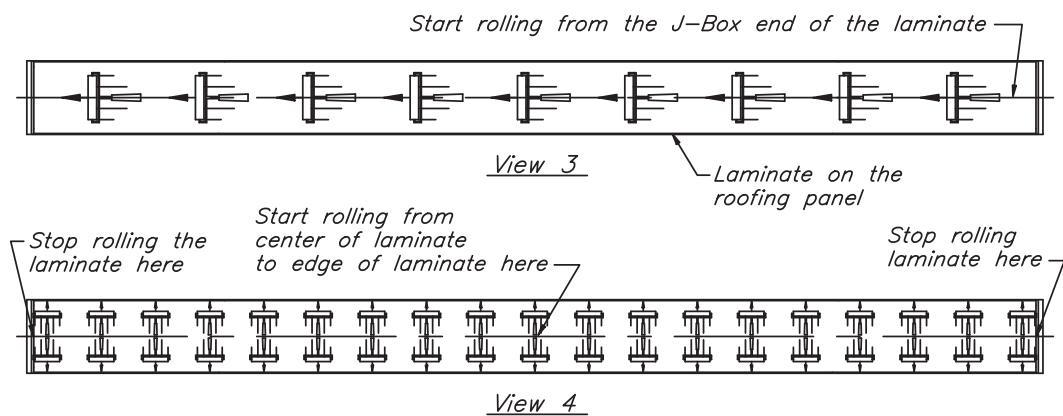

PVL Modules supplied with Factory "Quick Connect" Wires and Terminals

6. The PVL Modules can also be supplied with J-Boxes with factory-installed Quick Connect wires and terminals. The J-Box is bonded to the laminate/steel pan assembly using the Top Mounted J-Box Instructions found in this manual. After the J-Box is mounted to the laminate / steel pan assembly, the modules are wired together using the Quick Connect wires and terminals. (See View 5a). See Addendum #1: wiring *UNI-SOLAR* PVL Modules with Quick Connect Terminals

NOTE: The Quick Connect terminals are meant to be used as interconnection devices only. They are not to be used as a means of disconnecting the solar array.

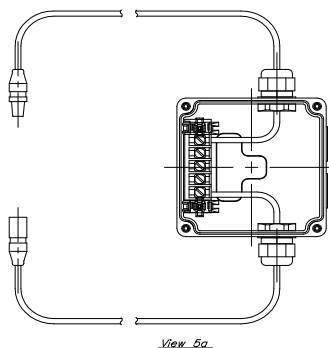

Top Mounted J-Box Installation

7. Make sure there is a piece of double-sided tape on the bottom of the J-Box (See View 5). If you have ordered the J-Box with Quick Connects, your J-Box will look like View 5a.

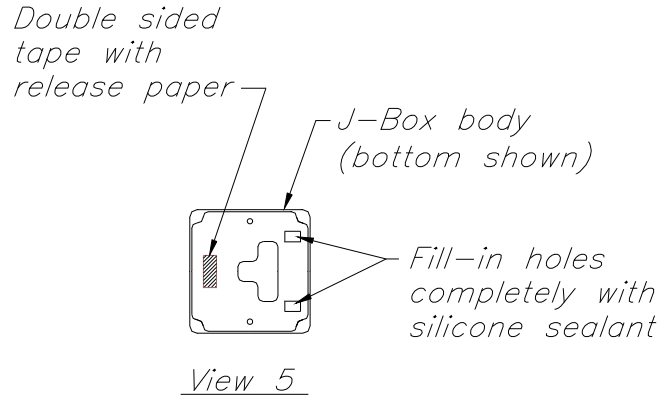

8. Place the J-Box on the laminate with the two (2) wires protruding through the opening on the bottom of the J-Box (see View 6)

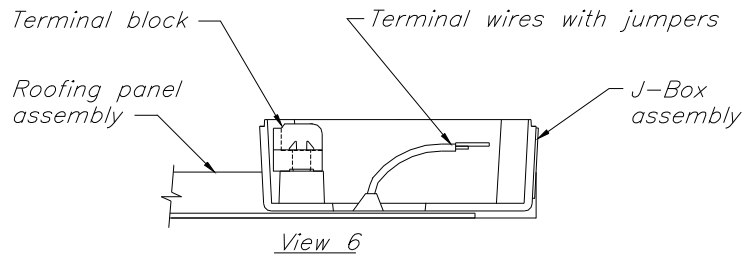

9. Center the two (2) termination wires on the laminate in the center of the opening on the bottom of the J-Box (See Enlarged View and View 7).

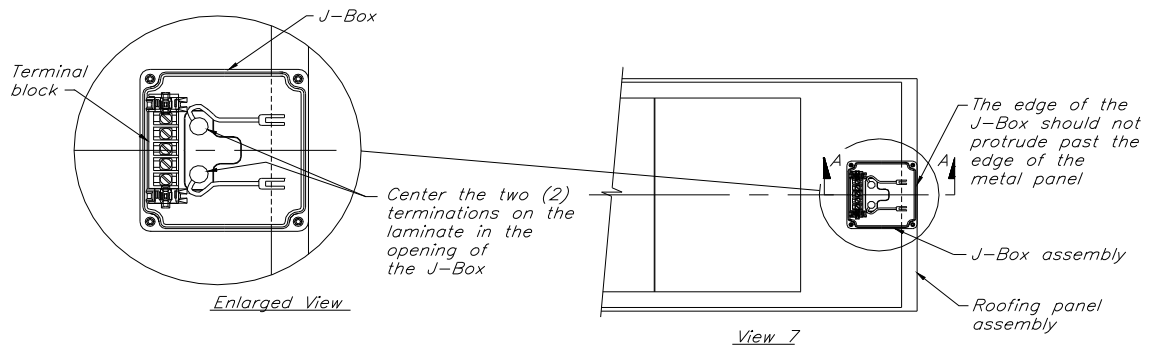

10. Make an outline of the box with a felt tip marker. After you have made the outline of the J-Box, set the J-Box aside (See View 8).

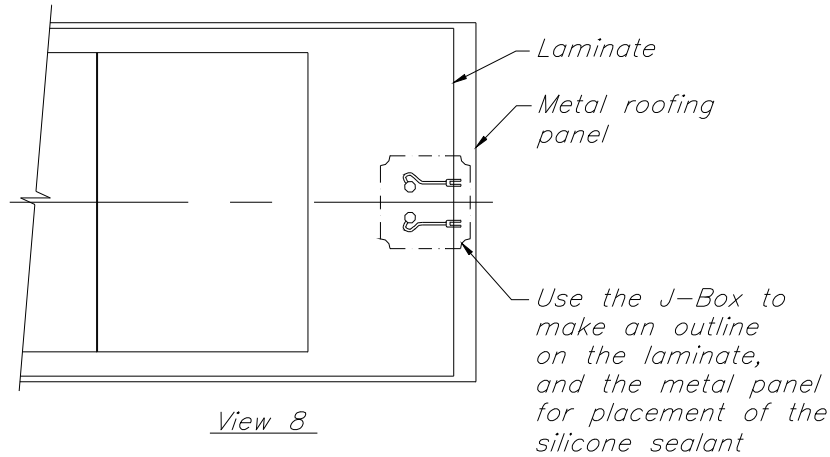

11. Fill in the two openings on the bottom of the J-Box with the supplied Dow 739 RTV silicone sealant (Black, 10.3 oz. USO Part # AA320879) (see View 5)

12. Apply the silicone sealant caulking just inside the marked position on the laminate and steel pan as shown in View 9 and the Enlarged View B. Apply a generous bead (1/4" x 1/4") of silicone sealant. Apply a small bead (1/4" x 1/8") of silicone sealant on the inside perimeter of the rectangular marking around the two (2) terminal wires (See Enlarged View B).

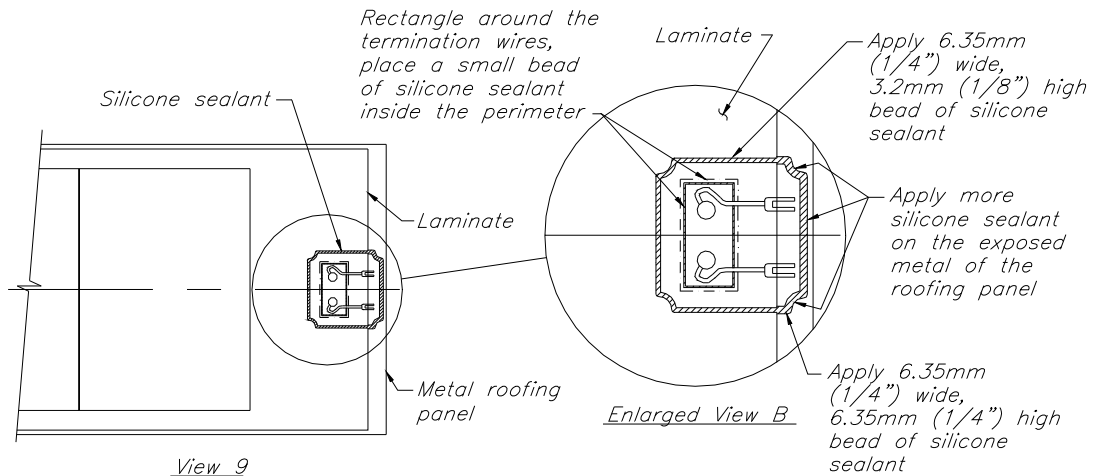

13. Make sure the sealant bead is continuous and uniform.

14. Remove the release paper from the double-sided tape on the bottom of the J-Box.

15. Align the J-Box case on the silicone sealant on the laminate and steel pan. Make sure the edges of the bottom of the J-Box are aligned properly with the silicone sealant on the steel pan.
16. Make sure that the two terminal wires are properly aligned with the opening on the bottom of the J-Box. The J-Box should be center matched, and edge matched with the steel pan (See View 10).

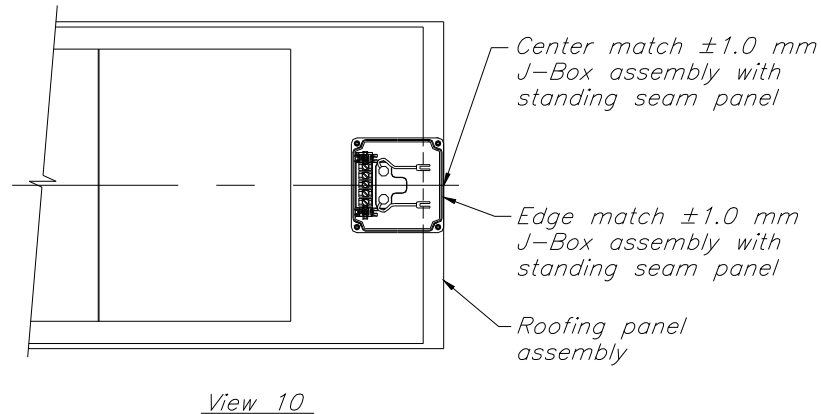

17. Check to make sure that the two terminal wires are not trapped or pinched between the J-Box case and the laminate.
18. Press the J-Box against the steel pan so that the double-sided tape on the bottom of the J-Box sticks to the PV laminate (the double-sided tape will hold the J-Box in place until the silicone sealant has fully cured).

NOTE: If you are required to use screws with the laminate (ex. high slope roofs in very hot climates), installers can use the screw penetration template included with their PVL shipment. A picture of the template is shown on page 7 of this manual.

19. Fill in the opening in the bottom of the J-Box completely with the silicone sealant up to the inside edge of the opening. None of the laminate should be exposed in the J-Box opening. Do not over-fill the opening with sealant (see View 12 and 13). The sealant should come up and over the edge slightly.

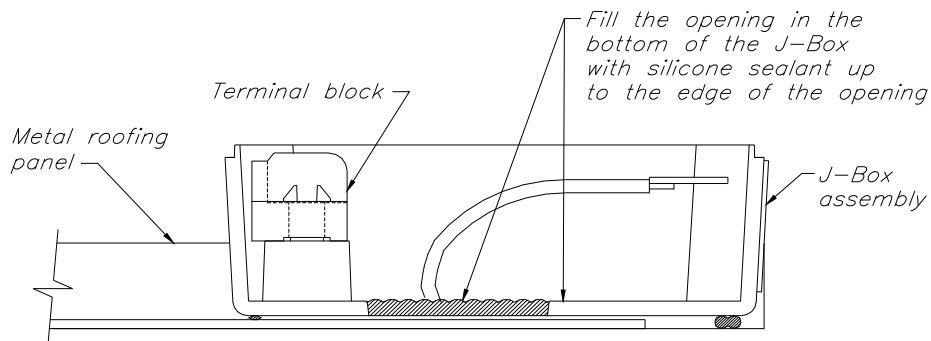

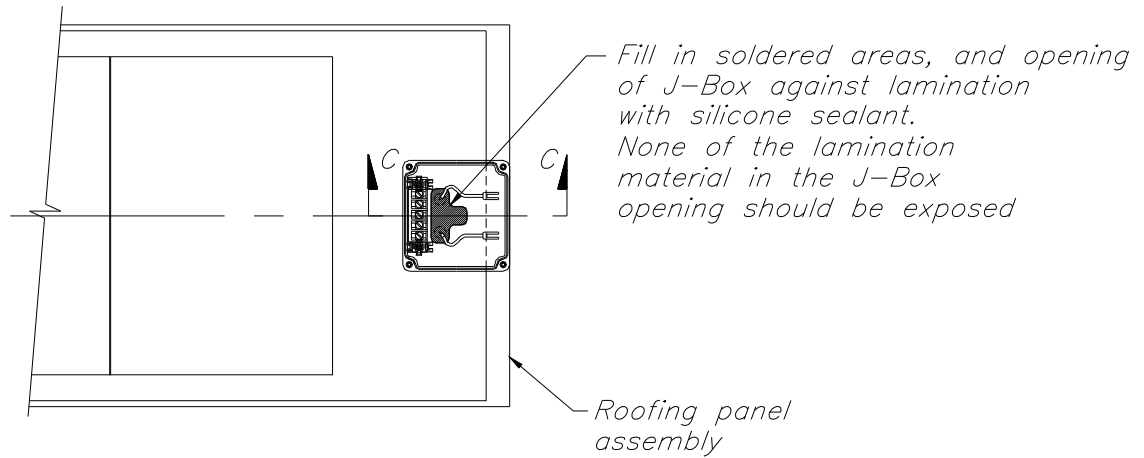

View 13

20. Place the J-Box lid on the top of the J-Box after allowing the silicone sealant to set up (“cure”). This will take approximately 8 hours.
21. Make sure the direction of the UNI-SOLAR logo on the J-Box lid is properly placed with respect to the steel pan (See View 14).
22. Screw down the four screws at the four corners of the J-Box lid. The recommended torque range for the J-Box cover screws is 14 ± 1 in-lb.

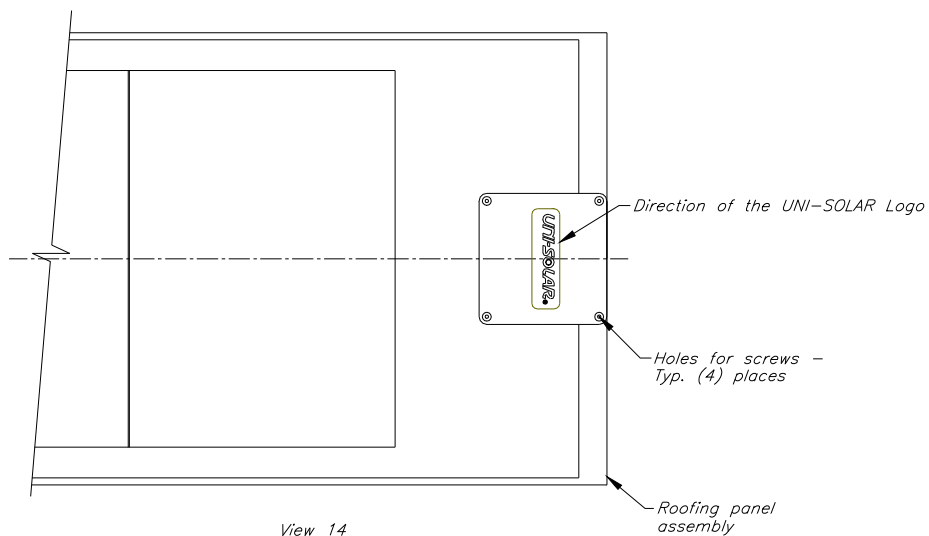

View 14

23. Screws for laminate penetration shall either be wood stainless steel screw #8 or wood screw #10; the torque shall be in the range of 20 to 60 in-lb

2.2 Detailed PVL Application Instructions – With Bottom Mounted Junction Box

NOTE: This option shall not be used on BIPV applications on buildings, but may be used for ground mount, or other open structures applications only, per NEC section 690.31.

Laminate Installation

1. Cut two (2) $\frac{3}{4}$ " (19 mm) holes in the metal panel for the terminations. The holes must be cut into the metal panel from the same side that the laminate assembly will be placed upon so that any burr is on the bottom side. The proper positioning of these holes is critical. There is just 1 mm of tolerance for the positioning of these holes, see View 15.

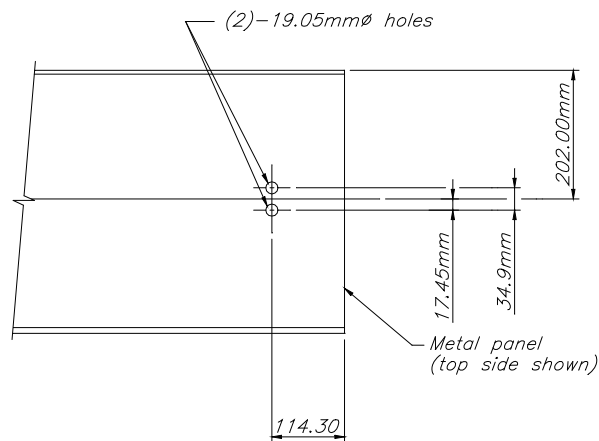

View 15

2. Remove any protective film from the face of the metal pan. Clean the metal pan with ISOPROPYL ALCOHOL (90% Alcohol - 10% Water) where the double stick and the laminate will be placed. If the pan is very dirty (material has been stored outside), the pan should be power washed with a cleaning solution (1/4 Cup Trisodium Phosphate, 1/2 Cup Detergent (ex. Tide®), and 5 gallons Water) and then rinsed before cleaning with alcohol solution

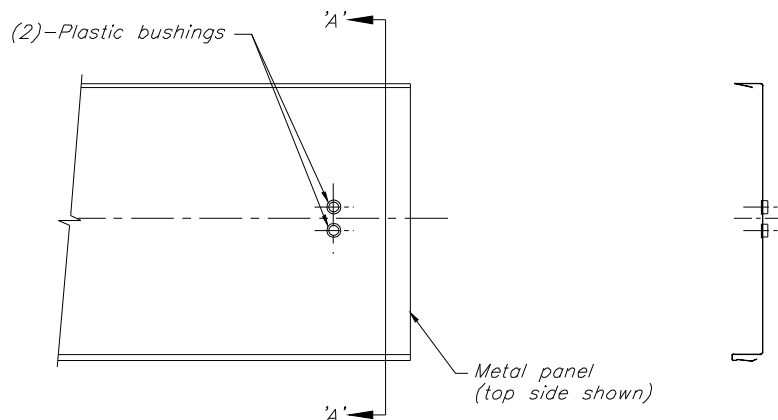

View 16

End View

3. Insert (2) two plastic bushings into the cut holes, one in each hole from the topside of the metal pan, see View 16 above.
4. The work surface should be flat and rigid. Make sure the end of the metal panel overhangs the flat rigid working surface just past the plastic bushing in the bottom of the metal panel.
5. Align the laminate and double stick assembly on the center of the metal roofing pan. The laminate assembly should be positioned approximately 1½ inches (38 mm) from the end of the metal panel, see View 17 below.

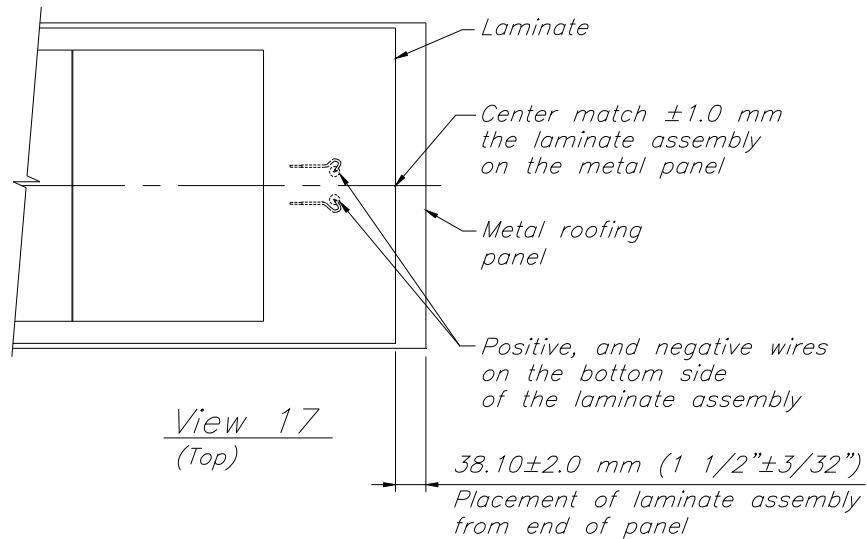

6. Then lift up the laminate and double stick assembly off the metal pan just past the edge of the wires (about 2" inches (51 mm) past the (2) two wires). Peel the release paper off of the double stick material approximately 6" inches (150 mm) and fold it under. Make sure the laminate is centered on the metal pan and the laminate assembly does not move on the metal pan during this process, See View 18. This is critical as **the laminate's position will be fixed after this first six inches is bonded to the metal pan.**

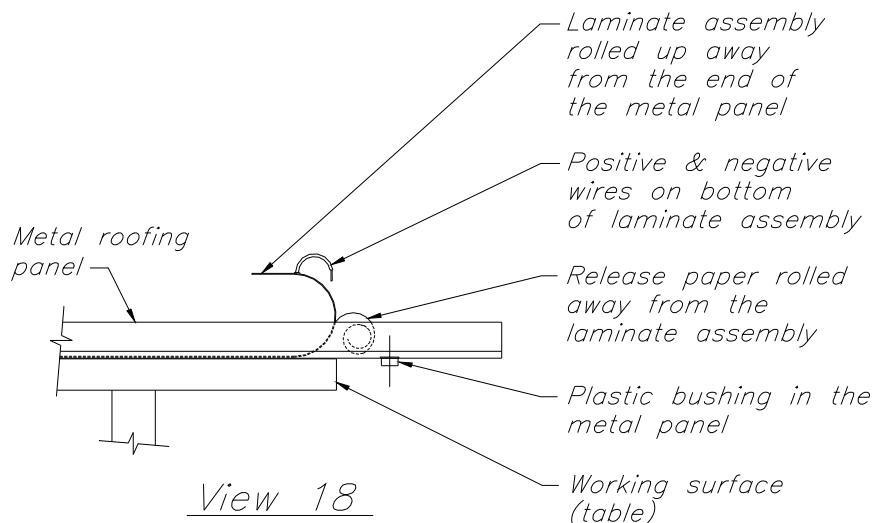

- Carefully roll the laminate assembly back onto the metal pan while placing the two (2) wires through the plastic bushings in the metal pan, see View 19. Stick the peeled end of the laminate assembly onto the metal panel.

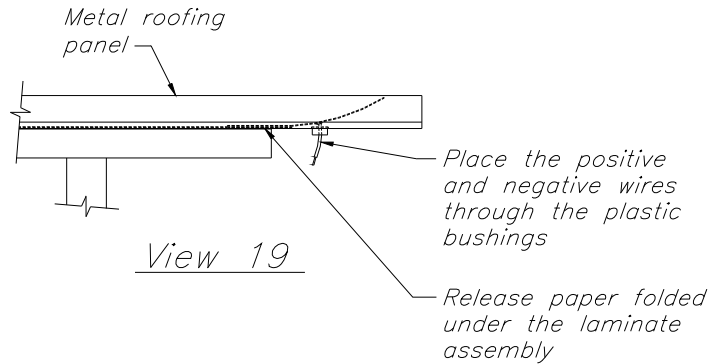

- Roll up the rest of the laminate assembly up to the stuck portion of the laminate. After the laminate assembly is rolled up on the metal pan, one person should peel the release paper from the bottom of the laminate assembly as another person unrolls the laminate onto the metal pan. Stick the laminate assembly against the metal pan, see View 20

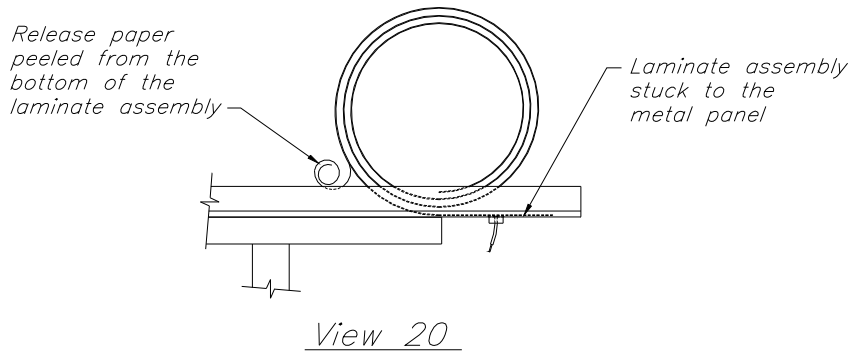

- After the laminate has been applied completely onto the metal pan, use a roller to press the center of the laminate against the metal pan. Then use the roller to press the laminate assembly onto the metal pan, starting from the center of the laminate and rolling out to the edges of the laminate, see View 21 and 22.

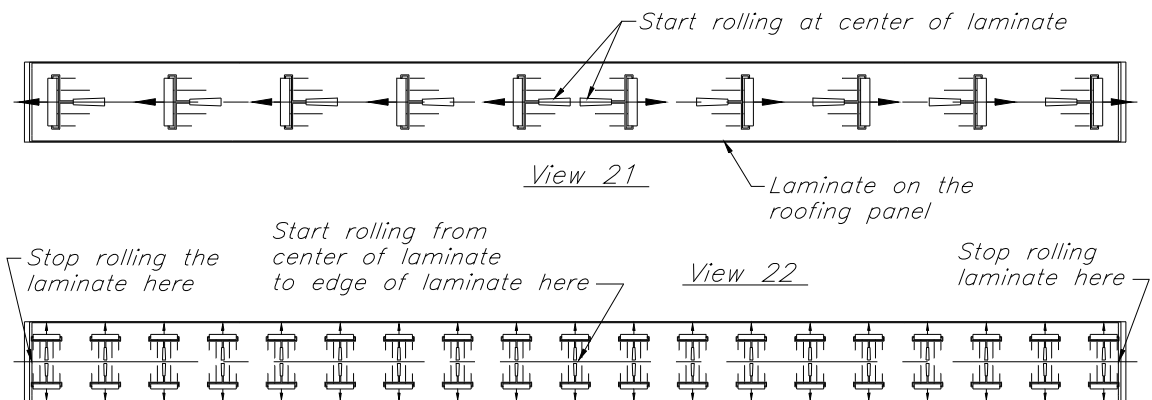

10. To prepare to place the J-Box on the metal panel assembly, turn over the metal pan so that the bottom side faces up.
11. Place the J-Box on the bottom of the metal pan with the two (2) wires and plastic bushings placed through the opening on the bottom of the J-Box, see View 24.

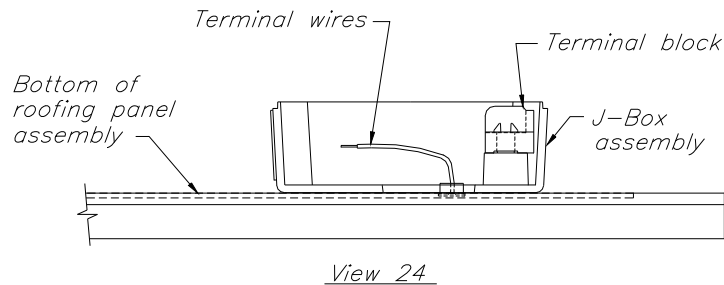

Center the two (2) plastic bushings and termination wires on the bottom of the metal pan in the center of the opening on the bottom of the J-Box, see View 25 and the Enlarged View, and make an outline of the J-Box on the metal pan, see View 26.

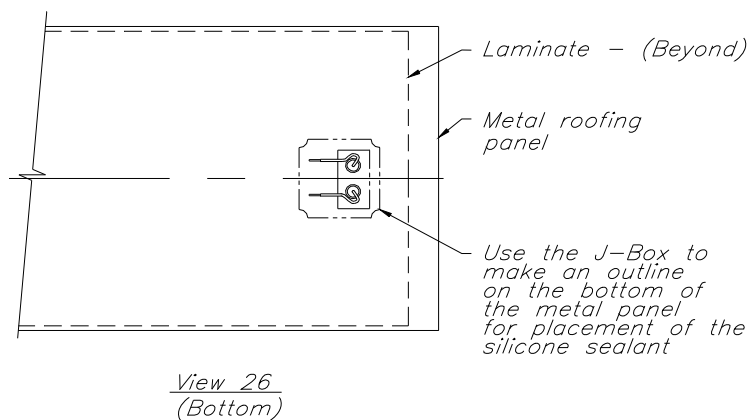
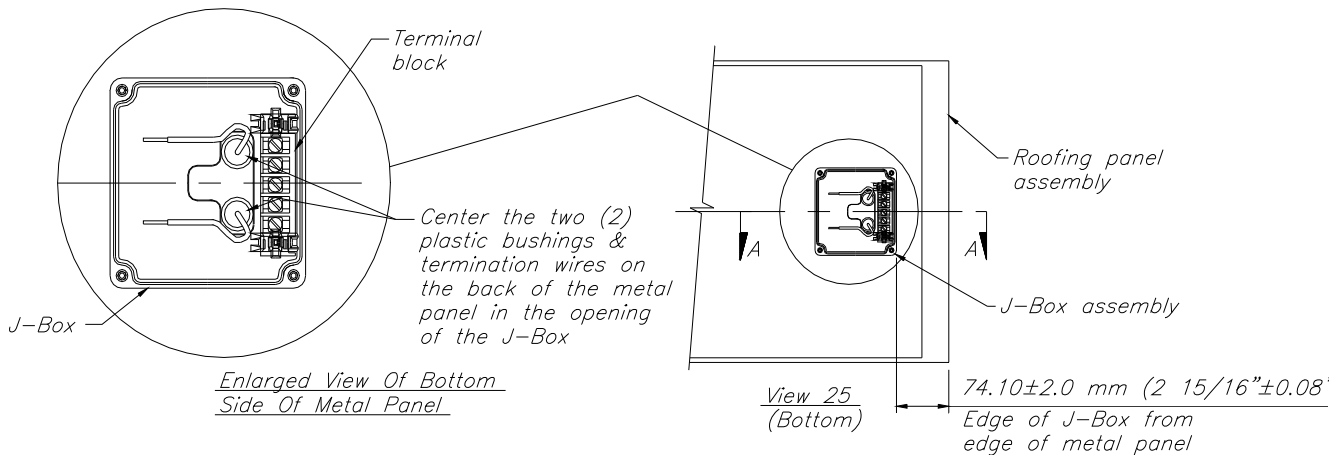

12. After you have made the outline of the J-Box on the bottom of the metal pan, set the J-Box aside.
13. Apply the silicone sealant caulking just inside the marked position on the laminate and metal pan as shown in View 27 and the Enlarged View B. Apply a generous bead ($\frac{1}{4}$ " x $\frac{1}{4}$ ") of silicone sealant. Apply a small bead ($\frac{1}{4}$ " x $\frac{1}{8}$ ") of silicone sealant on the inside perimeter of the rectangular marking around the two (2) terminal wires (See Enlarged View B).
14. Make sure that the sealant bead is continuous and uniform.
15. Make sure there is a piece of double sided tape on the bottom of the J-Box. Fill in the two openings on the bottom of the J-Box with silicone sealant, see View 27 below. Remove the release paper from the double sided tape on the bottom of the J-Box.

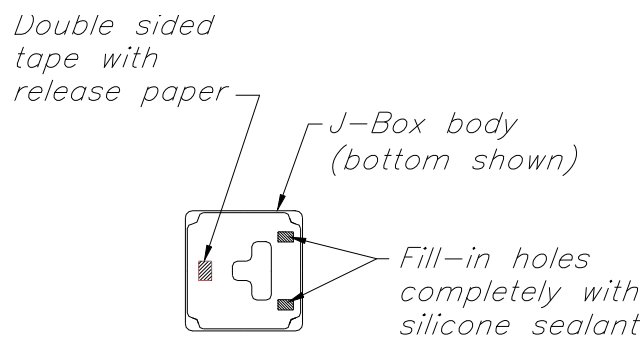
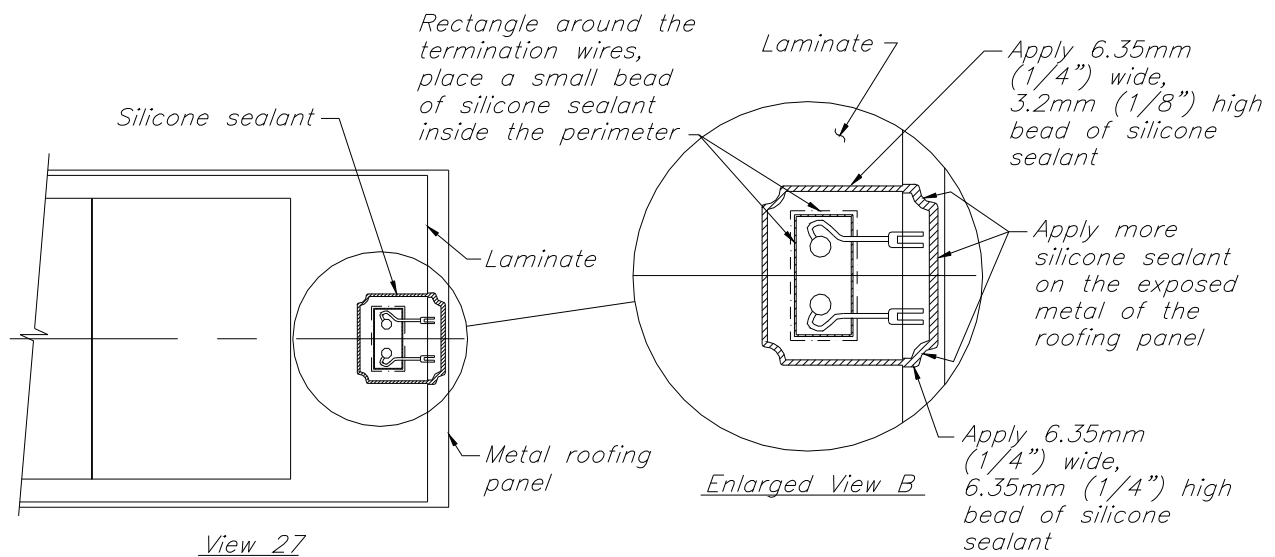

16. Place a wood block 2 x 4 x 10" inches long beneath the metal panel (between the PVL laminate and the working surface) in the area below the outline of the silicone sealant to help support the pan when applying the J-Box assembly, see View 28.

17. Align the J-Box case on the silicone sealant on the metal pan. Make sure the edges of the bottom of the J-Box are aligned properly with the silicone sealant on the metal pan.

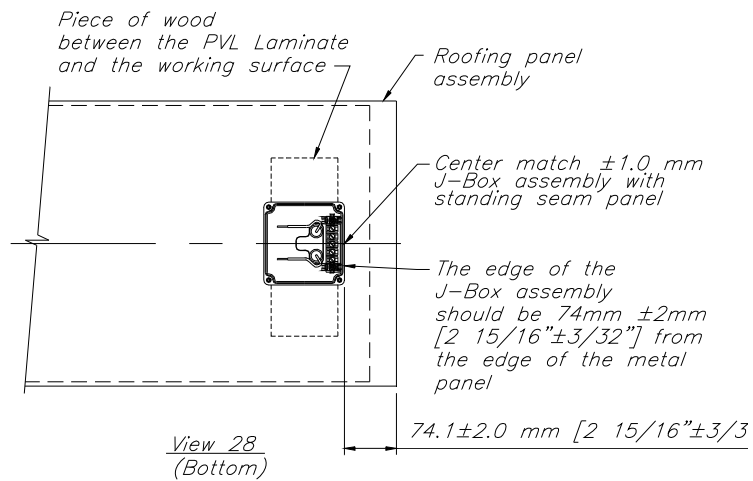

18. Make sure that the two terminal wires are properly aligned within the opening on the bottom of the J-Box. The J-Box should be center matched and $2 \frac{15}{16}$ ths (74 mm) from the edge of the metal panel.
19. Check to make sure the terminal wires are not trapped or pinched between the J-Box case and the bottom of the metal pan.
20. Press the J-Box against the bottom of the metal pan so that the double-sided tape on the bottom side of the J-Box sticks to the metal pan.
21. Completely fill the opening in the bottom of the J-Box, including the inside and outside of the two (2) plastic bushings with silicone sealant, up to the inside edge of the opening. None of the metal pan should be exposed in the J-Box opening. Do not overfill the opening with sealant, see View 29 and 30. **NOTE: You must allow the silicone sealant to set up ("cure") for at least eight (8) hours before attaching the J-Box cover.**

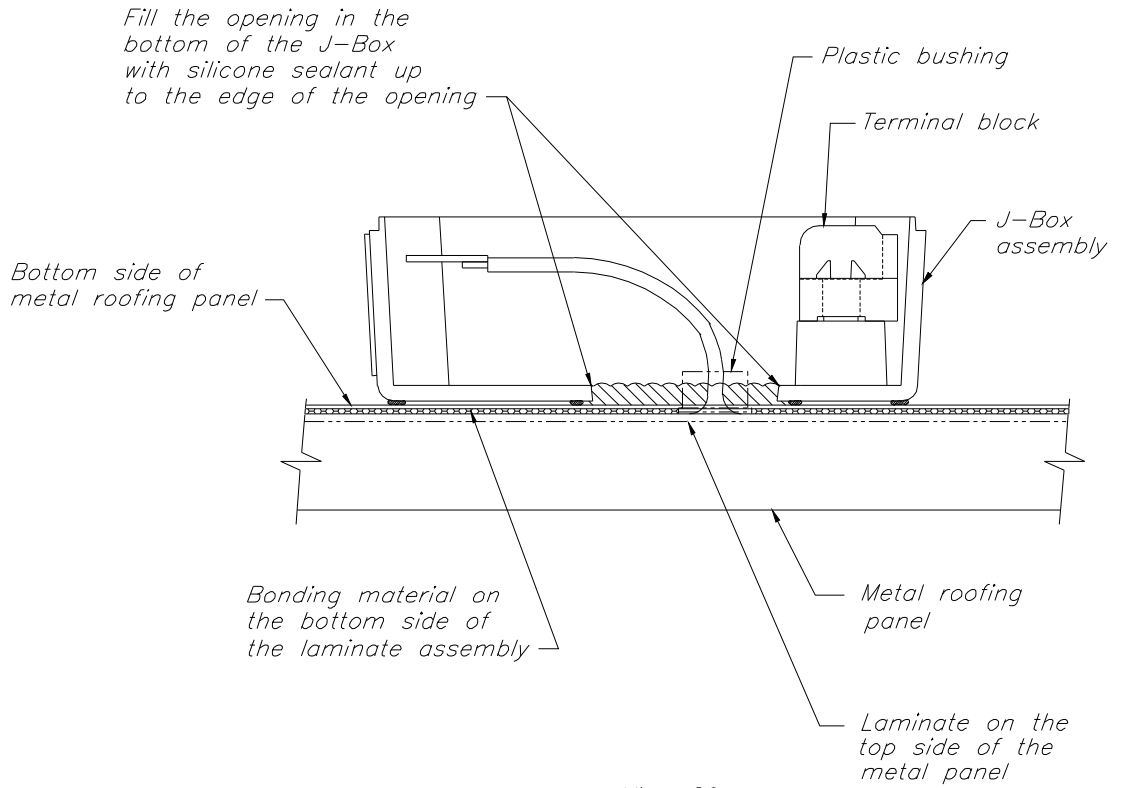

View 29

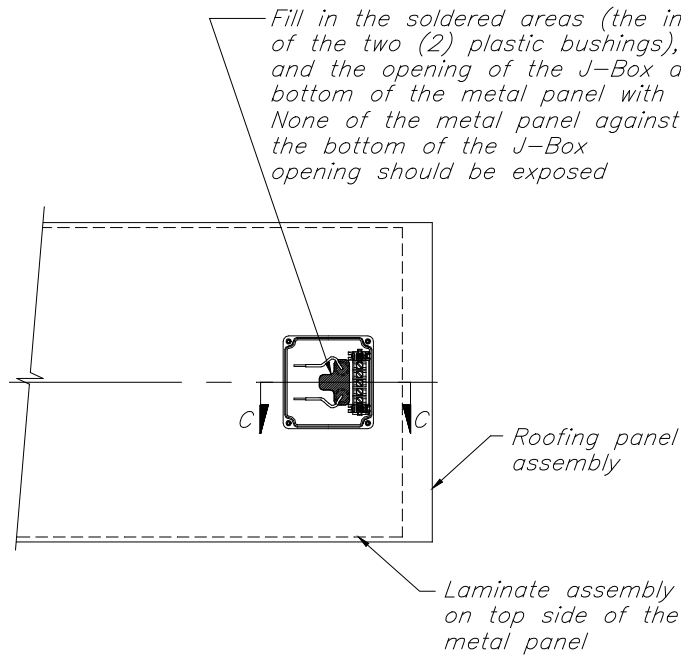

View 30
(Bottom)

22. Place a J-Box lid on the top of the J-Box body.
23. Make sure that the direction of the UNI-SOLAR logo on the J-Box lid is properly placed with respect to the roofing pan.
24. Screw down the four screws of the four corners of the J-Box lid. The recommended torque range for the J-Box cover screws is 14 +/- 1 in-lb.

SECTION 3

3.1 PVL with Quick Connects (MC®)

1. Most PVL modules are supplied with factory-installed module interconnect wires with MC Quick Connect (Cat No. PV-KBT3IIUR & PV-KST3IIUR) terminals. These terminals are marked “+” and “-” and will only fit into each other one way (See Addendum 1: Wiring UNI-SOLAR PVL Modules with Quick Connect Terminals).
2. It is required that additional strain relief for the wires be installed in the field. Mounting pads with cable ties are supplied with the laminates. The mounting pad comes with an adhesive that is used to bond the mounting pad to the steel pan just above the laminate. The plastic cable ties (2) are then tightened around the wire to secure the connection from being pulled loose.
3. Instructions for applying Mounting Pads –
 - a) Apply a thin layer of 3M 94 Primer or equivalent over the area where the cable mounts are to be secured. Allow the primer to flash off before installing the mounting pads.
 - b) Peel off release liner and place first cable mount into position. Position the mounting pad directly in line with the interconnect wire to allow the wire to lay straight.
 - c) Remove the release liner on second cable mount and place into position directly in line with the other interconnect wire.
 - d) Thread two cable ties into one mounting pad. Place one of the interconnect wires in center of mounting pad and tighten cable ties by hand.
 - e) Using Hellermann-Tyton cable tension tool, tighten first the cable tie that wraps directly around the wire. Tighten to the highest setting recommended by the manufacturer.
 - f) Tighten the second wire tie.
 - g) Repeat the process for the second cable mount and ties.

Refer to View 31

NOTE: The Quick Connect terminals are to be used as interconnection devices only. They are not to be used as a means of disconnecting the solar array.

4. PVL modules are wired together into strings of modules by plugging in a number of modules together, in series, positive to negative, to form a higher voltage string of modules. (600V max)
5. Two penetrating screws (#12-1, self tapping, 5/16th inch, hex head with sealing washer) can only be put in certain areas at the top of the laminate. Installers should use the screw penetration template to guide them (see View 11).

Notes:

Cable ties - Hellerman Tyton
part #T30RQUVH4
U.L. recognized components

Mounting Pad - Hellerman Tyton
(Adhesive and screw type)
part #MB4AQUVA2H4 or MB4QUVH4
(adhesive and screw type),
U.L. recognized components

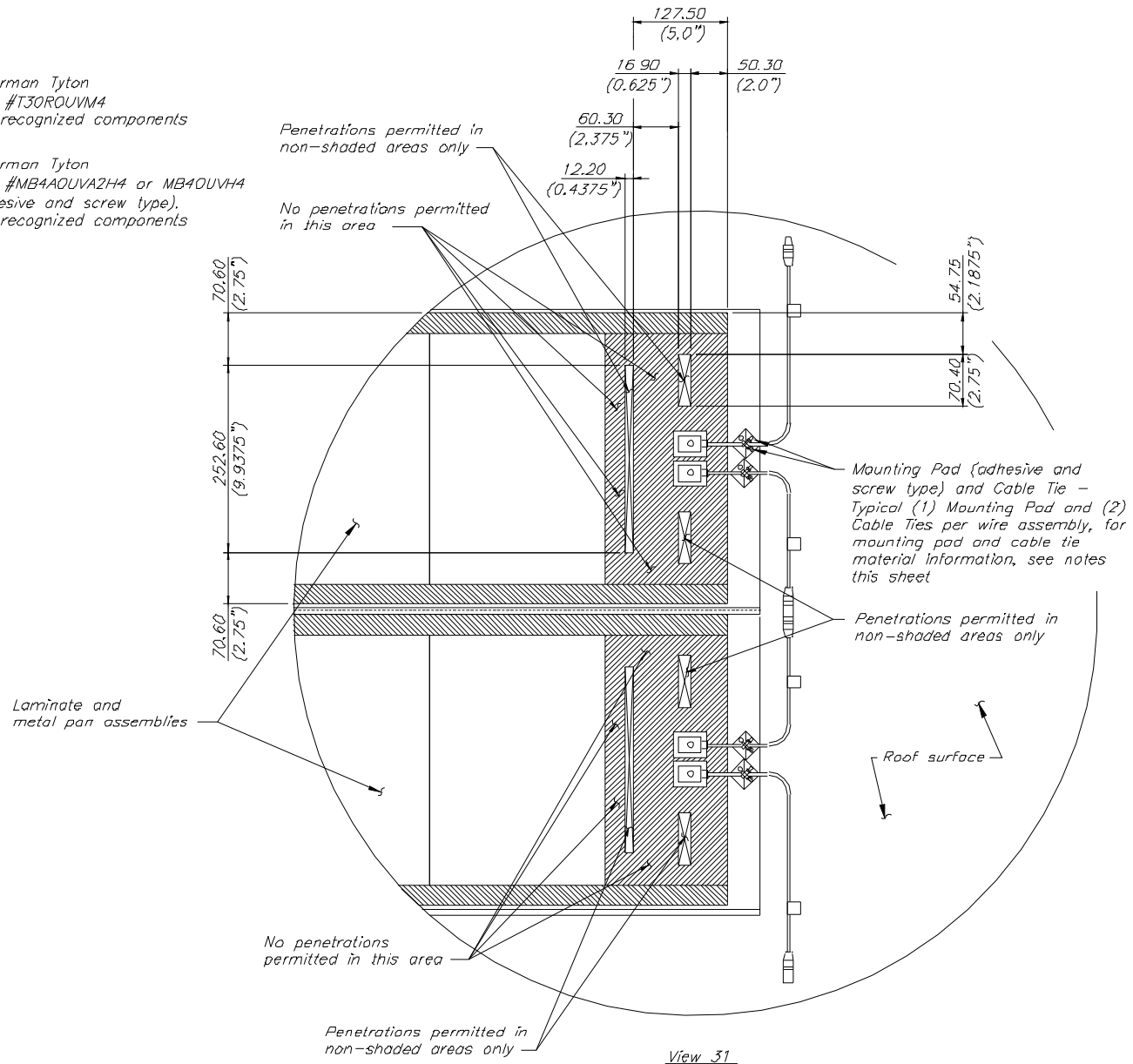

SECTION 4

4.1. General Wiring Instructions for PVL Modules

Wire Selection

- 90°C, wet rated conductors are necessary. If modules interconnect wires are exposed under the ridge cap, use conductor type USE-2. If module interconnect wires and/or cables going from the modules to the combiner box are to be run inside of a wire chase, you can use RHW-2, THWN-2 or XHHW-2 conductors. Another option is to use PV Cable/PV Wire listed to UL 4703.
- Temperature de-rated ampacity calculations for the DC side of your PV system should be based on 156% of the short-circuit current (Isc), and the de-rated ampacity must also be greater than the rating of the over-current device. Refer to the NEC Article 690.

DC Wiring Configurations (48 Volt and High Voltage)

NOTE: If your solar modules come with “Quick Connect Wires and Terminals, see the Quick Connect Wiring Addendum at the end of this manual.

- The UNI-SOLAR module j-box contains five terminal screws. The first screw on the left (as you look into the box) is the positive terminal. The last screw on the right (as you look into the box) is the negative terminal.
- The second, third and fourth terminals are not wired to the active material in the module and can be used as extra spaces for wiring after installation of “jumpers” included with the hardware of every module.

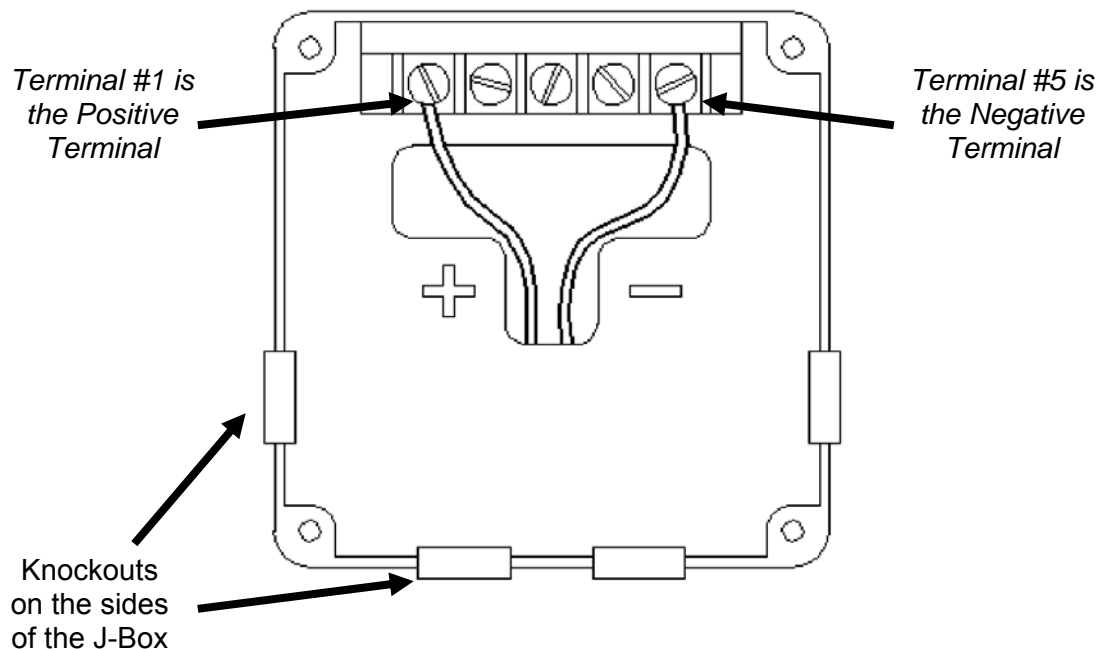

- Modules can be configured using series wiring, parallel wiring, or a combination of series and parallel wiring.
- Prior to entering the dwelling, the source circuits must be contained in metal conduit. Refer to NEC for guidance.

Grounding

- Section 690.5 of the NEC requires that systems with PV modules on the roof of a dwelling have ground fault protection equipment.
- Grounding of the standing seam metal pans to which the PVL modules have been adhered can be accomplished with the use of grounding clamps (IlSCO GBL-1/0, or equivalent). The ground clamp can be fastened to the metal roofing pan seams by ¼" stainless steel machine screws with star lock washers and nuts.
- Grounding of metal parts where the photovoltaic laminate or PV source wire (USE-2 or equivalent) are passing under or over (in close proximity or otherwise come in contact with), can be accomplished with the use of grounding clamps as described above, or by other listed methods meeting KDER and NEC requirements.
- The equipment-grounding conductor will need to be bonded to earth via a ground rod. The conductor can be bare copper or insulated with green colored insulation. The conductor should be sized according to Table 250-122 in the NEC.
- PV source circuits must be terminated in a terminal box and then run in metal conduit prior to entering dwellings. See NEC for further guidance.

- Please refer to the National Electric Code for further guidance related to all wiring associated with the photovoltaic system.

4.2. Four Termination (Wiring) Options for PVL Modules on Steel Roofs

There are 4 basic options for wiring PVL arrays:

- ✓ Ridge Termination
- ✓ Mid-roof Head Flashing
- ✓ Mounted Wire Channel/UL listed Wire Way
- ✓ Engineered Snow Retention Channel.

| Termination Option | Allowed Slopes | Allowed Locations | Comments |
|---|--|--|---|
| Ridge Termination | $\geq 3,5^\circ - \leq 60^\circ$ | No restrictions | Standard when Z-closures are used. |
| Mid-roof Head Flashing | $\geq 18^\circ - \leq 60^\circ$ $\geq 14^\circ - \leq 60^\circ$ | In snow country. In no snow country. | Metal roof pans need to be cut to the length of the laminate. |
| Mounted Wire Channel/UL listed Wire Way | $\geq 3,5^\circ - \leq 60^\circ$ | Not in snow country unless rated for snow retention. | Allow by assessment where screws are not needed for that roof! |
| Engineered Snow Retention Channel. | $\geq 18^\circ - \leq 60^\circ$ | No restrictions | Only when a mid roof channel has been selected as the termination option. |

Option 1. Ridge Termination

Ridge caps are a standard component on metal roofs. Ridge terminations are the preferred method of wiring PVL arrays because they offer easy access and superior aesthetics at minimum cost.

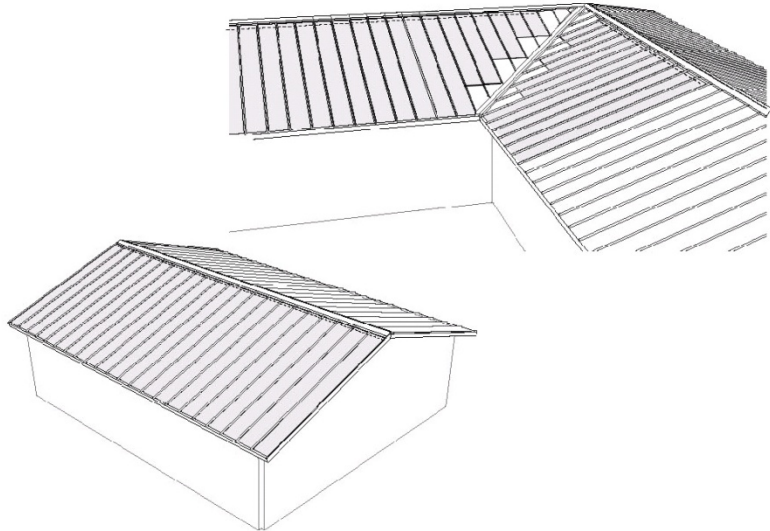

Examples of roofs with ridge terminations

Ridge termination installation instructions:

After laminates have been bonded to pans, roofing pans are installed as usual. Refer to Installation Guide for location of allowable penetration area. If a Z-closure is used to secure the ridge cap use two screws to mechanically fasten the Z-closure, taking care to drive screws into allowable area only.

Insert Quick Connects terminals into ridge and plug to adjoining Laminates to create series strings. Dimensions of ridge cap will be determined by the distance between the Z-Closure and the ridge. Secure ridge cap.

Similar installation procedures are used for high side trim for shed roofs, and sidewall trim for roof-to-wall conditions.

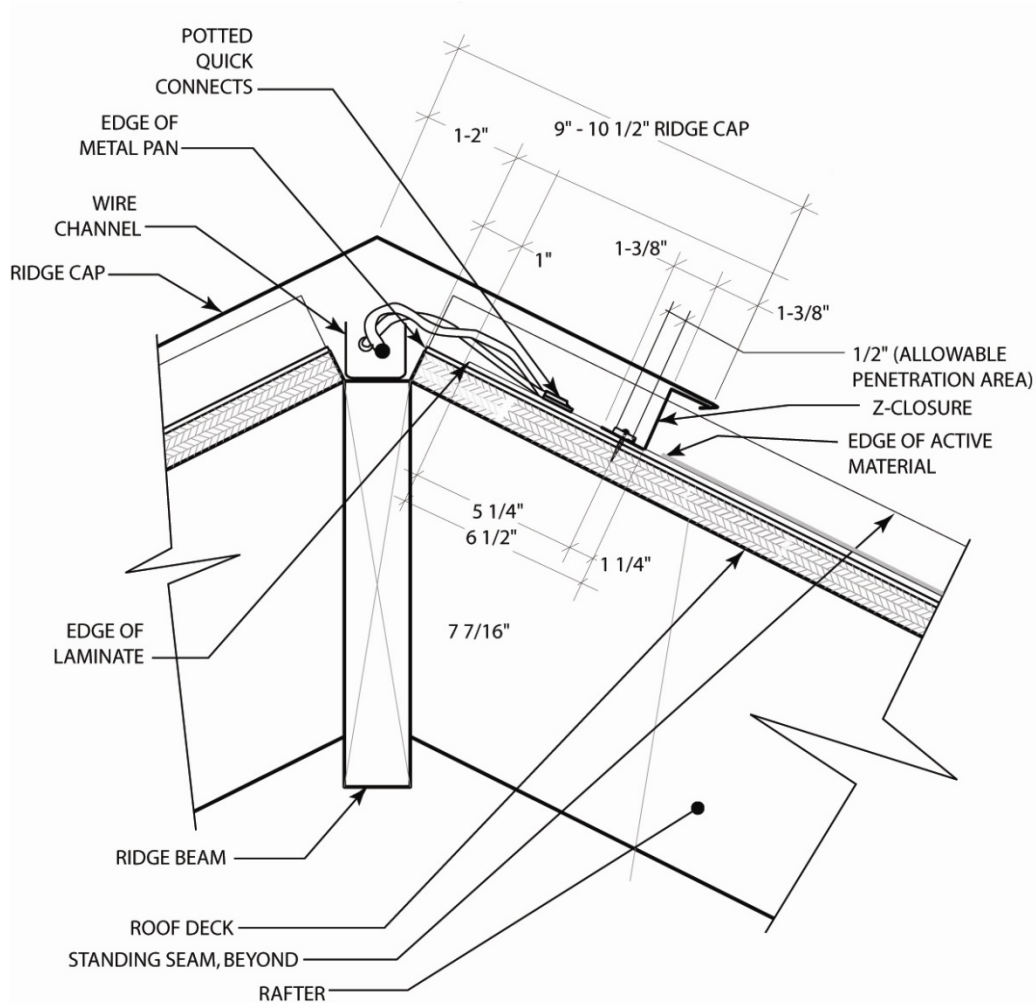

Section through ridge showing placement of Z-Closure.

NOTE: required strain reliefs not shown

Vented Ridge Cap:

- 1) Hold ridge cap on peak and mark where lip of cap hits the roof.
- 2) From your marks, measure 2" towards the peak and snap a line.
- 3) Place Butyl strip just below the line.
- 4) Place baffles, then the Z-bar onto the Butyl strip so that the back of the Z-bar lines up with the snapped line.
- 5) Screw baffles and Z-bar down with screws installed 5" from each rib.

Wiring can now be done.

- 6) Apply cap, starter piece with 90-degree liquid tight strain relief cord and cable connector, if needed, and pieces lapping.
- 7) Screw through front lid of cap into Z-bar using screws as described in 2.1.23



Installing Z-Closure, taking care to put screws through areas where penetrations are allowed



Installed Z-Closure, ready for quick connection



Vented Z Closure



Vented Ridge Cap

Option 2. Mid-roof Head Flashing

A head flashing is a standard metal roofing detail used to make a transition in slope or roofing material. Low profile quick connects can fit easily under a head flashing. Most roofs do not require a head flashing detail, therefore this option adds cost to the installation and can compromise the aesthetics. Using a mid roof head flashing further means that the metal roof pans, which are usually continuous, must be cut to the length of the laminate and installed separately. Additionally, head flashings can only be installed on roofs that are over 4:12 (18 °) in slope in snow country and 3:12 (14 °) in areas without snow.

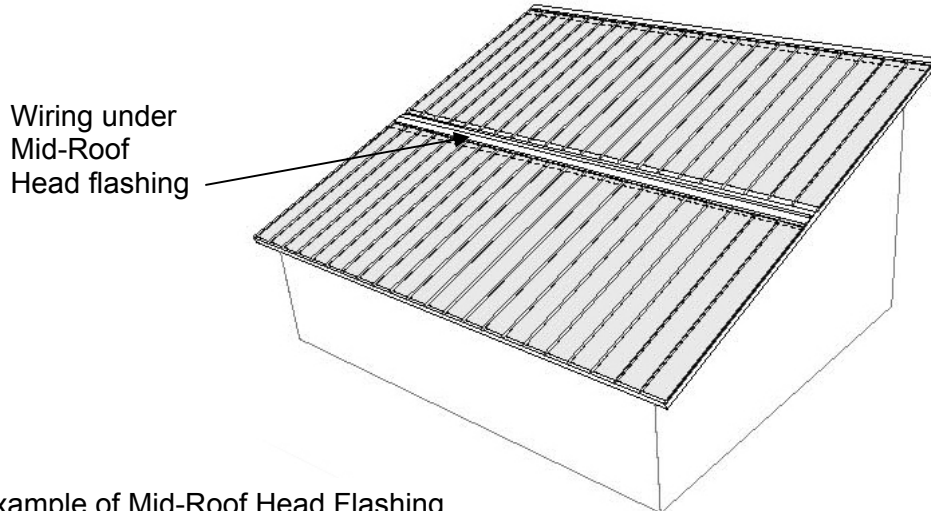

Example of Mid-Roof Head Flashing

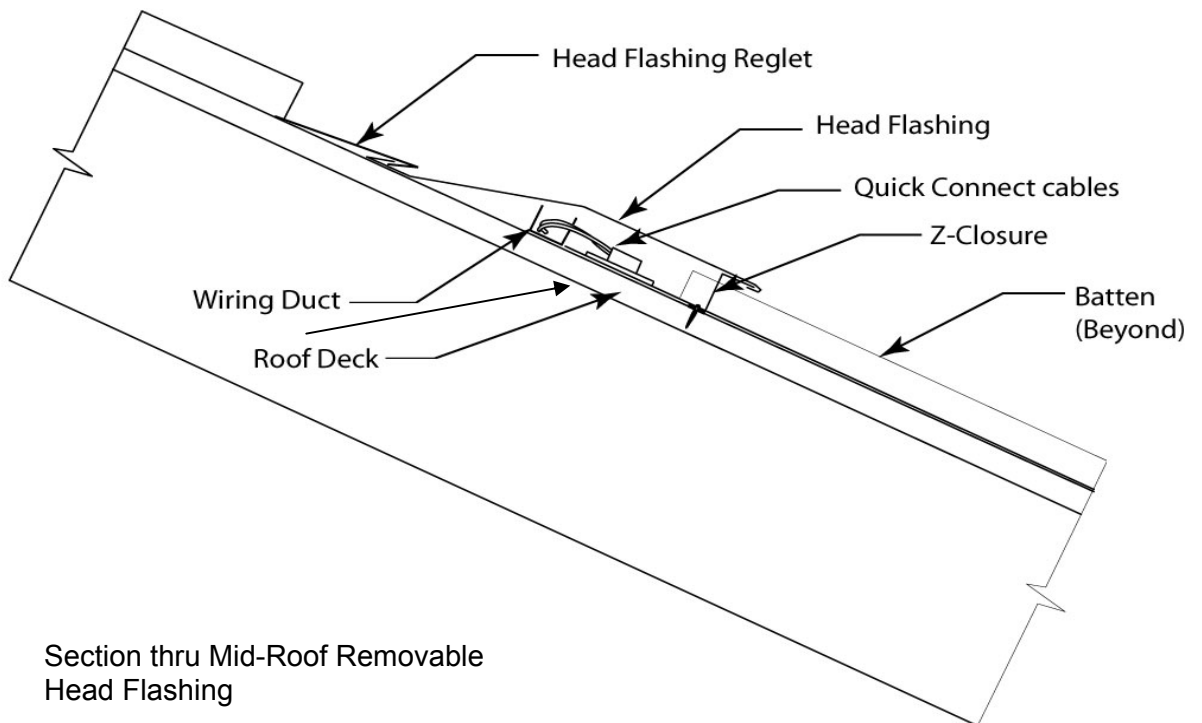

Section thru Mid-Roof Removable Head Flashing

Mid-Roof Head Flashing Installation Instructions:

After laminates have been bonded to pans, bottom row of roofing pans are installed as usual. Refer to Installation Guide for location of allowable penetration area.

- 1) Secure Z-Closure with two screws, taking care to drive screws into allowable area only.

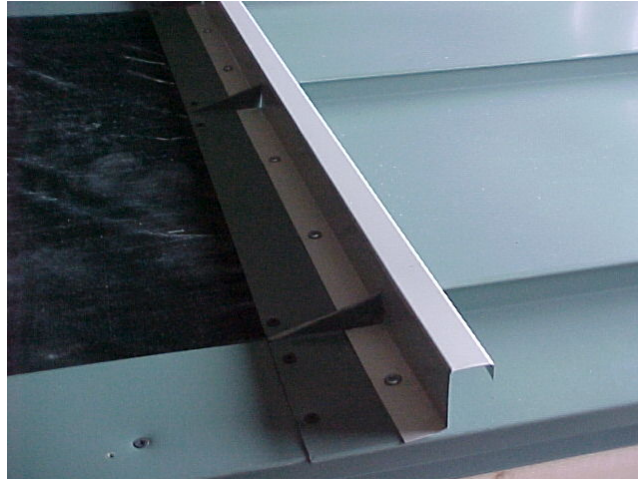

Z- closure

- 2) Insert Quick connects and plug to adjoining laminates to create series strings.
- 3) Place the head flashing tight to front edge of the Z-Closure.
- 4) At both sides of the roof make a mark on the roof deck by drawing against the back edge of the flashing.
- 5) Remove the head flashing.
- 6) Measure down towards the Z-Closure 2-1/2" from the marks and snap line.
- 7) Line up the front edge of the reglets with the line and attach them to the roof with roof nails in the top edge.
- 8) Push head flashing into reglet until they snap together.

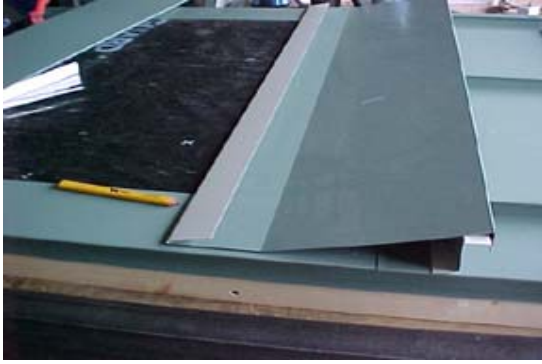

Head flashing before assembly

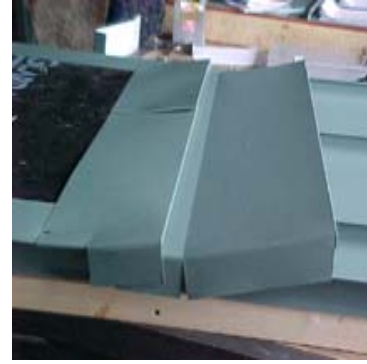

Head flashing after assembly

9) Pull the head flashing forward, clip it onto the Z-bar and screw them together with small screws through the front of the head flashing.

10) Butt head flashings together as they are applied and add joiner strips.



Butt joint



Joiner strip

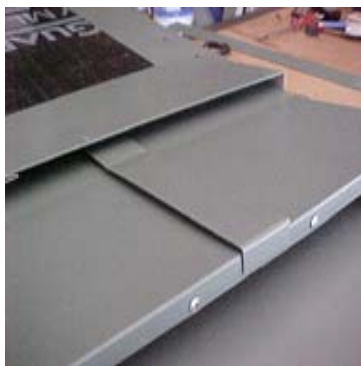

Finished Butt Joint



Installation of Starter Cleat

Option 3. Mounted Wire Cover / UL listed Wire Channel

On large roofs that will have a row(s) of laminates without ridge or eave access a mounted wire cover can be used to conceal wire connections run in a UL listed wire channel. This option can be applied on low slopes down to 3.5° (3/4:12) and full length metal pans can be installed. Mounted wire covers cannot be used in snow country unless they are rated for snow retention. While this wiring option is less expensive compared to head flashing, it still may compromise aesthetics and should probably be limited to low slope applications where the roof will be less visible. On large roofs, the termination ends of the laminates can be butted end-to-end and connected in one wire raceway to minimize the number of wire channels necessary.

Attachment: The attachment of wiring channel systems to a metal roof system can be achieved with standard beam clamps or with blocks made for snow retention and air handling systems such as the S-5! mounting blocks. Again the material that the mounting block or clip is made out of has a large bearing on the price. UNI-SOLAR recommends aluminum S-5! mounting blocks.

Wire Channel installation instructions:

- 1) After laminates have been bonded in an end-to-end configuration on the metal roofing pans, the S-5! Clamps are attached to every other standing seam directly above the joint where the laminates butt together.
- 2) The wire cover should be pre-punched so that the proper size holes are centered on each pan.
- 3) The wire channel is then attached to the S-5! Clamps and the quick connects are run up through bushings in the holes in the wire channel.
- 4) The quick connects are then plugged together in the desired series strings.

Wire channel covers can be fabricated out of the same metal as the roofing. This allows the use of less expensive wire channels. The cover can be secured to the top of the channel to both protect the wires and reduce the visual impact of the channel. Please refer to the

CAUTION!!



Although this type of wiring channel is raised above the standing seams and there is space below the wiring channel for snow to slide off the laminates and roof, the wire channel could act as a snow stop in northern climates. Although the wire channel and clamps/clips depicted in this system are strong, there is no engineering at this point that accurately describes the snow loads it can handle. It is recommended that on steeper pitches in northern climates either a rated snow retention bar accompany this system or that a head flashing be used.

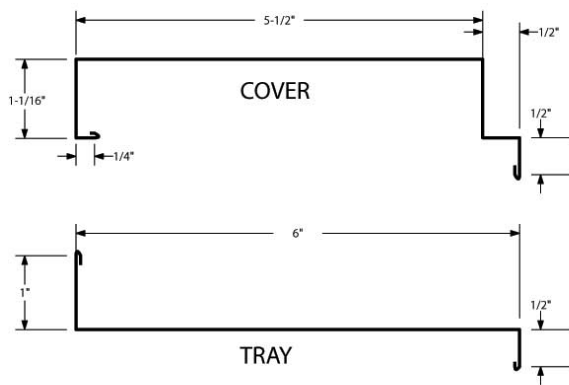
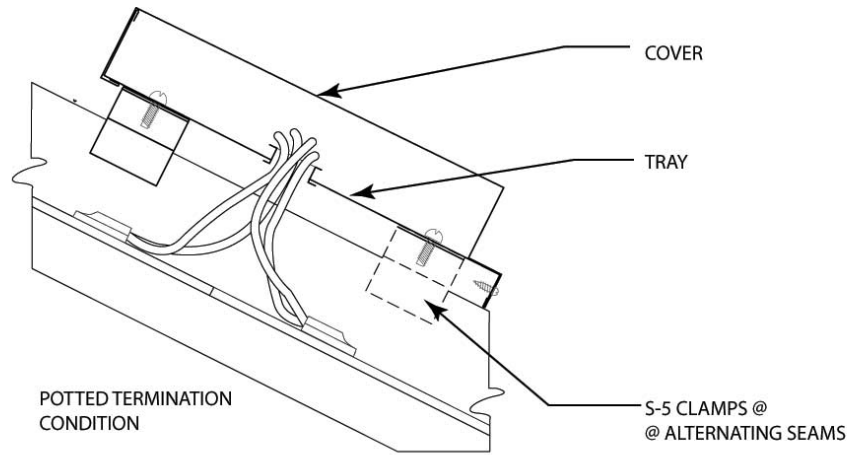

SECTIONS THROUGH
**MID-ROOF
 WIRE COVER**
 SCALE: 1" = 2"

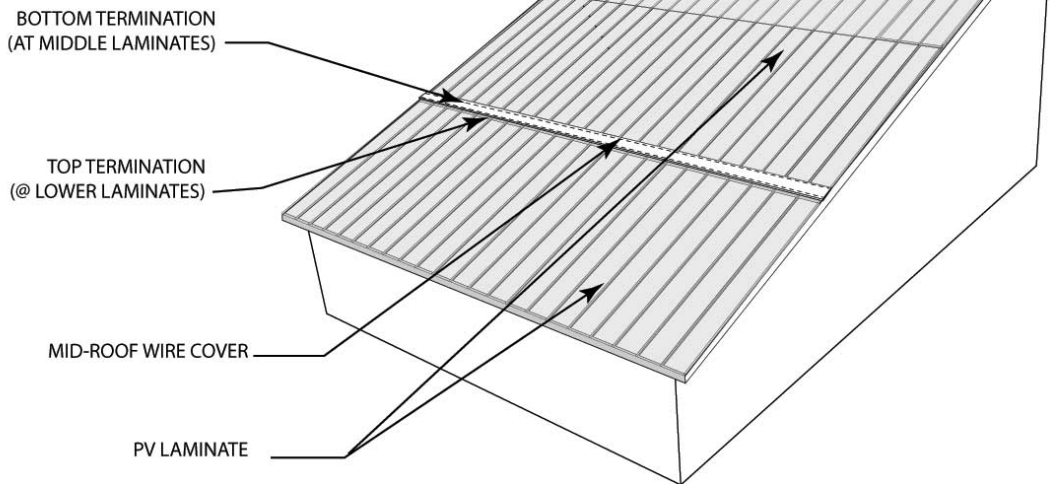

Option 4. Engineered Snow Retention Channel

In snow country where mid-roof wire channel has been selected as the termination option, a snow guard retention system will be required to protect the wire channel from damage. On projects where snow retention is required for safety reasons, a snow guard retention system in combination with a wiring channel may be a good option. In general, snow should be shed from solar arrays as quickly as possible to maximize performance.

Snow Guard Retention Channel Installation Instructions:



Mounting Blocks Installed



Snow Guard Channel in Place

- 1) Place the snow guard channel on blocks.
- 2) Mark holes and pre drill with a 3/8" bit.



Hole Drilled in Channel



Channel Fastened

- 3) Fasten snow guard channel with snow diverters in place onto mounting blocks with 9/16" bolt and washer.
- 4) Prepare wire channel for use.

5) Snap wire channel into snow guard channel and wire up.



Wire Raceway Applied to Snow Guard

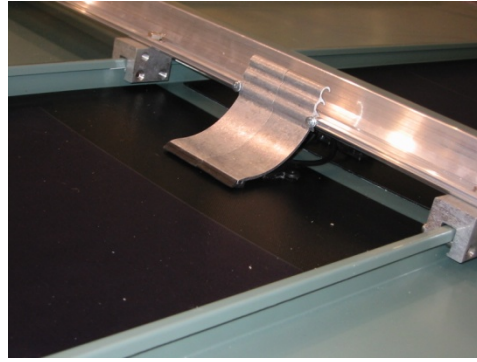

Snow Guard protects wiring

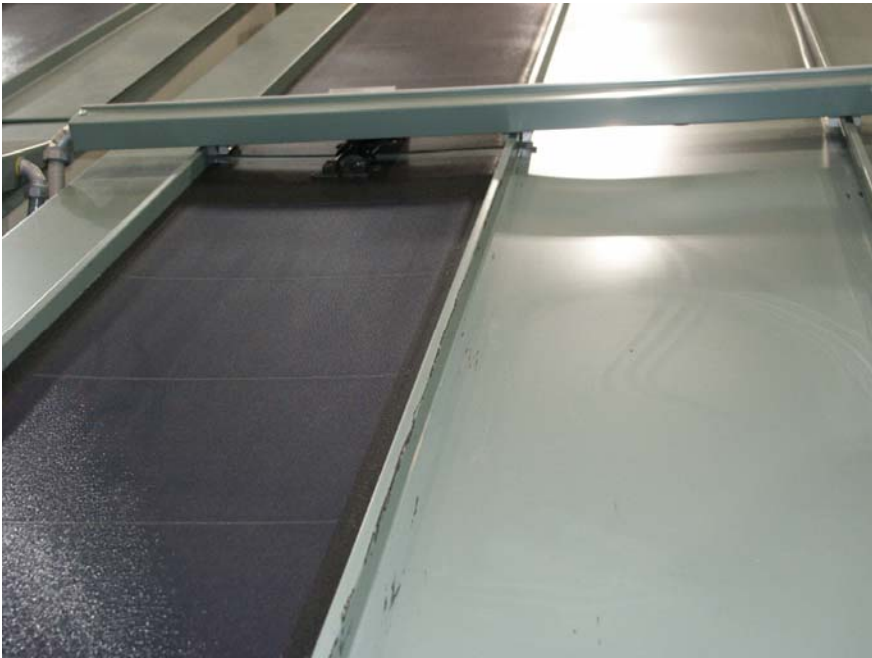

4.3. Maintenance

Steel Panels with PV Laminates

- When working on a roof, ensure that proper fall protection equipment and appropriate safety practices are followed if required. When working on the solar panels, always wear electrical gloves rated for the maximum rated system voltage (i.e. 600 VDC), disconnect all energy sources (i.e. battery and/or utility) and short-circuit the output of the PV panels.
- Periodically check panel wiring connections for tightness and corrosion. The best time to check is just before and/or just after the winter (or rainy) season.
- Generally, a good rain is sufficient to clean the PV panels. However, in dusty arid locations the PV panels can be cleaned with water or mild soap and water. Do not use abrasive soaps or solvents.
- Do not spray water directly at leading edge of the PV panel. Use caution when cleaning PV panels, as the combination of water and electricity may present a shock hazard. Always wear electrical gloves and avoid cleaning the panels in the middle of the day.

System Commissioning and Troubleshooting

- With disconnect switches closed, record all system meters and status indicators.
- With the multi-meter, check array voltage and current at the Combiner Box or other convenient place within the system.
- Check for open circuit breakers or blown fuses.
- Open disconnect switches and use your multi-meter to confirm that the power is actually cut off.
- Check for loose wires or connections at the solar system array controller (voltage regulator).
- Remove cabinet covers and visually inspect all equipment wiring.
- Close all disconnect switches and make sure loads are operating as designed.
- Clean balance-of system components (i.e. inverters, disconnect enclosures, etc.) and loads once a year or as required.
- Confirm that no new loads have been added to the system and that loads are operating for the specified number of hours per day.

SECTION 5

5.1. Addendum #1: Wiring UNI-SOLAR PVL Modules with Quick Connect (MC[®]) Terminals

Subject

Proper use of the UNI-SOLAR Quick Connect Assembly, for use with modules that have factory-installed “Quick Connect” terminals on *UNI-SOLAR* PVL and Power Module interconnect wires.

Introduction

UNI-SOLAR Power Modules and PVL products can be supplied with “Quick Connect” terminals on factory-installed module interconnect wires. “Quick Connect” terminals are designed for exterior use and are UV resistant.

Although “Quick Connects” are well designed for fast connection of modules into groups (i.e. “strings”) of modules, **“Quick Connects” are not designed to be used as module disconnects.**

For each Quick Connect cable, there is a strain relief mounting pad and cable tie to provide strain relief. The mounting pad is installed in the field and adhered to the roofing material (not directly on the laminate surface) near the potted terminal cover located at the base of each quick connect cable.

Installation Instructions

Using the UNI-SOLAR Quick Connect Assembly and the instructions below, PV system installers are prepared for safely connecting PV module strings to balance of system components.

The UNI-SOLAR Quick Connect Assembly contains 2 pieces: a Male Cable Coupler Assembly and a Female Cable Coupler Assembly, both of MC3 type (Cat. No. PV-KBT3IIUR & PV-KST3IIUR).

After series connecting (positive to negative) individual Power Modules or PVL’s together into a group (“string”) of Modules, there will be a male “Quick Connect” on one end of the string and a female “Quick Connect” on the other end of the string of modules.

1. Determine that the group (“string”) of solar modules has the correct number of modules connected together (maximum system voltage 600 Vdc)
2. Install the Quick Connect strain relief pads and route the module interconnect wire through the cable tie loop. Tighten so that the wire is held firm
3. Find the male “Quick Connect” on one end of the string and the female “Quick Connect” on the other end of the string.

4. Attach appropriate outdoor-rated conductors to the ends of the *UNI-SOLAR* Cable Coupler Assemblies using standard wire terminals designed for exterior use.
5. Route positive and negative PV conductors to appropriate balance-of-system (BOS) components
6. Attach the *UNI-SOLAR* Male Cable Coupler Assembly (MC3) on one end of the string.
7. Attach the *UNI-SOLAR* Female Cable Coupler Assembly (MC3) on the other end of the string.
8. Refer to section 4.1 for the grounding of all metal roofing parts in close proximity to USE-2 source circuits.
9. PV source circuits must be terminated in a terminal box and then run in metal conduit prior to entering dwellings. See NEC for further guidance.

Technical Information:

- 1) Withdrawal and Plug-In Force:

For new Cable Couplers, the withdrawal force is ≥ 50 N and the insertion force is ≤ 50 N. The values may vary after a number of plugging cycles. Ensure you are not pulling on the potted terminal covers.

- 2) Rated Current:

Maximum rated current is 8 amps for the *UNI-SOLAR* Male and Female Cable Coupler Assemblies.

- 3) Maximum System Voltage:

Maximum voltage for a *UNI-SOLAR* PV system and the *UNI-SOLAR* Male and Female Cable Coupler Assemblies is 600 VDC.

Quick Connect Assembly: Drawings and Bill of Materials

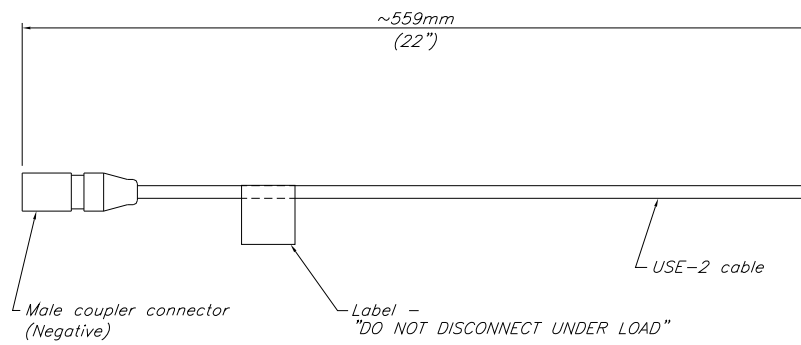
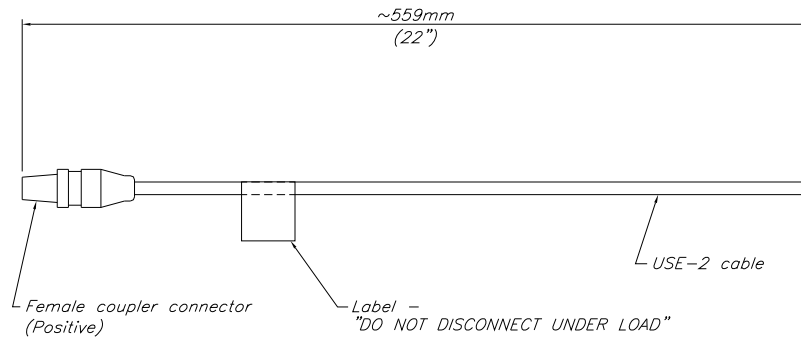

5.2. PVL Installation Check List and Final Report

The purpose of this Report is to certify that the undersigned installer has completed installation of *UNI-SOLAR* PVL Laminate described below in accordance with the manufacturer’s installation guidelines and has fully complied with the PVL bonding instructions.

To ensure that the PVL laminate was properly installed, it will be required that all Certified PVL Installers copy the Installation Checklist and Final Report from this manual, fill in the Checklist and Report after installation of the product at any given site. The Check List and Report is then signed, dated and returned to:

United Solar Ovonic LLC
BIPV Applications Engineering Department
3800 Lapeer Road
Auburn Hills, MI 48326

Installation Location:

Customer / Project Name:.....

Site Address:.....

Customer Telephone / Email:

Application of the PVL Product:

| QUESTION | YES | NO |
|--|---------|----|
| 1. If the PVL application will take place on an existing roof, were the pans washed with a pressure sprayer and cleaning solution (ex. TSP, Detergent and Water) to remove collected dirt, pollen, grime etc.? | | |
| 2. Were the pans washed with Isopropyl Alcohol (90% alcohol to 10% water) before application of the laminates? | | |
| 3. Was the pan temperature at least 10°C (50°F) during the bonding process? | | |
| 4. Were all laminates aligned properly on the pans? | | |
| 5. Did all the laminates adhere to pan completely? | | |
| 6. Was every square inch of the laminate pushed down to the metal pan surface with the laminate roller to ensure a complete bond to the metal pan? | | |
| 7. Was the J-box or Quick Connect Terminals aligned properly? | | |
| 8. Were Strain Reliefs provided and were they installed as shown on Page 24? | | |
| 9. Did the laminates come with Quick Connect Terminals, a standard J-Box or a J-Box w/ Quick Connects? | | |
| 10. How long did it take (on average) to bond the laminate and J-Box to the pan? | Minutes | |

Post-Installation:

| QUESTION | YES | NO |
|---|-----|----|
| 1. Did the roofer install the pans properly? | | |
| 2. Was there any damage to the solar module (laminates) during installation? | | |
| 3. Are any ripples or other defects in the PVL application seen from the ground? | | |
| 4. Is the J-Box or Quick Connect wiring adequately protected from UV by metal roofing trim (or an approved wire cover)? | | |
| 5. Has the PV installation been approved by the local building department? | | |

System Information:

| QUESTION | |
|--|--|
| 1. What is the operating voltage of the PV array? | |
| 2. Which laminates were installed at this site (PVL-29, PVL-58, PVL-64, PVL-87, PVL-116, or PVL-128)? | |
| 3. How many PVL laminates were installed on the UL Listed Roofing System at this site? | |
| 4. What type of inverter was installed at this site? | |
| 5. What type (if any) of battery was installed at this site? What is the total amp-hour capacity of the battery? | |

Note to Installer:

The quality and acceptance of PVL installations are the prime responsibility of the installer. United Solar Ovonic LLC reserves the right to inspect any and all installations to verify the accuracy of this report. Providing inaccurate or misleading information will cause immediate cancellation of the installer's certification.

Installer:

Signature:.....Date:...../...../.....

Name:.....

Address.....

Telephone:

Email:

Contacts:

United Solar Ovonix LLC

Corporate Office
3800 Lapeer Road
Auburn Hills MI 48326
(800) 843-3892
(248) 475-0100
Fax (248) 364-0510
www.uni-solar.com

United Solar Ovonix LLC

North American Sales Office
8920 Kenamar Dr. Suite 205
San Diego, CA 92121 USA
Tel: 858.530.8586
Fax: 858.530.8686
Email: westerninfo@uni-solar.com

United Solar Ovonix LLC

United Solar Ovonix Europe GmbH

Trakehner Str. 7-9
D-60487 Frankfurt/Main
Phone: +49-69-7137667-0
Fax: +49-69-7137667-67
Email: europeinfo@uni-solar.com

Southern European Sales Office

United Solar Ovonix Europe GmbH

c/o Via Brigaldara 20
1-37029 San Floriano
Verona - Italy
Tel/Fax: +39.045.6838165
Cell: +39.346.7204844
Email: mvancleef@uni-solar.com