

UNI-SOLAR®

POWERTILT INSTALLATION GUIDE

PVL on Metal and PowerTilt Assembly



PowerTilt System Installation Guide

UNITED SOLAR OVONIC

The *UNI-SOLAR*® Photovoltaic Laminate Series and Power *Tilt* Installation Guide for a Variety of Roofing Materials

Disclaimer of Liability

The information contained in this manual is based on United Solar Ovonics knowledge and experience, but such information and suggestions do not constitute a warranty expressed or implied. The methods of installation, use and maintenance of roofing surface are beyond the control of United Solar Ovonics. United Solar Ovonics assumes no responsibility and expressly disclaims liability for any loss, damage or expense associated with the use, installation or operation of the solar system. Any liability of United Solar Ovonics is strictly limited to the Limited Warranty. United Solar Ovonics reserves the right to make changes to product specifications or to this manual without notice.

© United Solar Ovonics LLC
2956 Waterview
Rochester Hills, MI 48309
Phone 248-293-0440 • Fax 248-844-1214
Toll Free US 800-528-0617

Table of Contents

Safety Warnings.....	1
Important Safeguards.....	2
Definitions	3
General Installation Notes.....	4
Top Terminated PVL with Quick Connects Application	7
Strain Relief and Terminal housing Cover	10
Power <i>Tilt</i> -Mechanical Assembly	20
General Roof Application Installation Notes	20
Array Assembly.....	22
System Grounding	30
Bonding Path Resistance Test.....	31
Designing and installing a Solar Electric System	33
System Operation and Maintenance.....	37
Photovoltaic Array and Wire Runs	38
External and/or Internal DC Disconnects and Combiner Boxes	39
Inverter and Transformer.....	39
AC Disconnect	40
PV Array Cleaning Procedure.....	41
Appendix A: PowerTilt Bonding Path Resistance Check Sheet.....	43
Appendix B: PowerTilt Array Layout Typical	44
Appendix C: Suggested Material and Tools List	45
Appendix D: Suggested Installer Assembly Order	46
List of Figures/Illustrations	47
List of Tables.....	48
Index	48

Safety Warnings

WARNING

This manual must be read and understood before attempting to handle, install, wire, operate, and perform maintenance to the laminates and Power Tilt system. The laminates produce DC electricity when exposed to sunlight or other light sources. Contact with electrically active parts of the laminate can cause injury or death whether it is connected to other laminates or individually. The installer assumes the risk of personal injury or property damage that might occur during the installation and handling laminates or Power Tilt system.

WARNING

To avoid product damage, personal injury, or even possible death, carefully read, understand, and follow all the installation and safety instructions before attempting to install, wire, operate the array, and perform maintenance on the laminates.

CAUTION

Observe all electrical safety precautions to prevent electrical shock while installing the laminates, performing wiring, testing, or maintenance of the PV array. Use insulated tools and proper personal protective equipment to reduce risk of electric shock

Important Safeguards

- ✓ To ensure a safe installation, contact the appropriate local authorities prior to installation to determine if permits and inspections are required in the jurisdiction of the installation. Installation shall be in accordance with NFPA 70, Article 690; Solar Photovoltaic Systems National Electric Code in the United States, or CSA 22.1 Safety Standard for Electrical Installations; Part 1 of the Canadian Electrical Code.
- ✓ DO NOT proceed if any doubt arises about the correct or safe method of performing anything found in this manual.
- ✓ It is the responsibility of any individual who installs or maintains this product to fully understand and follow proper installation and maintenance procedures.
- ✓ Uni-Solar PV laminates contain electrical components enclosed and protected within. Do not cut or trim or alter in any way. Do not drive screws into any part of the photovoltaic laminate. Altering the laminate or improper installation could cause electric shock, may result in fire, and will void the warranty.
- ✓ Do not connect or disconnect quick connect cables under load as an arc flash could occur.
- ✓ Do not attempt to concentrate sunlight on the laminates for increased output as damage may occur and will void the warranty.
- ✓ Cover PV laminates with an opaque material before making wiring connections to reduce the risk of electric shock or arc flash.
- ✓ Observe proper polarity when connecting the PV laminates into an electrical circuit. Reverse connection will damage the PV laminates, may result in fire, and will void the warranty.
- ✓ Avoid dropping sharp objects or placing objects on the laminates as damage may occur that may result in fire and will void the warranty.
- ✓ Remove all metallic jewelry during installation of the system and while performing any electrical or maintenance work to reduce the potential for injury and the potential of accidental exposure to live electrical components.
- ✓ Be sure to use personal protective equipment, such as sturdy leather work boots, preferably with steel toes, cut-resistant or leather gloves, chemical resistant gloves, safety glasses and hard hat, and knee pads if necessary.
- ✓ The edges of the laminate and assembly may be sharp and handling may result in lacerations. Wear the proper personal protective cut-resistant gloves or leather gloves when handling this product.
- ✓ When installing panels above ground, follow appropriate safety practices in accordance to fall protection safety and using required safety equipment. Do not handle assemblies during periods of high wind.
- ✓ Do not install this product when the laminates are wet or in the presence of standing water on membrane roofs. Installing this product without drying all surfaces or in the presence of water could cause you to slip and personal injury can result. Before installation, ensure that the roof surface is dry.
- ✓ Personal injury can result from tripping over power cords, tools, electrical conduit, natural gas lines, or installation materials. Ensure that the work is clear of trip hazards.
- ✓ Follow all manufacturers' instructions or MSDS sheet for the safe use of isopropyl alcohol. Personal injury can result from improperly handling or use of products such as isopropyl alcohol. Alcohol vapors are both flammable and hazardous to breathe and may cause irritation to the eyes, nose, throat and skin.

Definitions

As per NEC (Article 690.2), the different elements of our systems are being defined as follows:

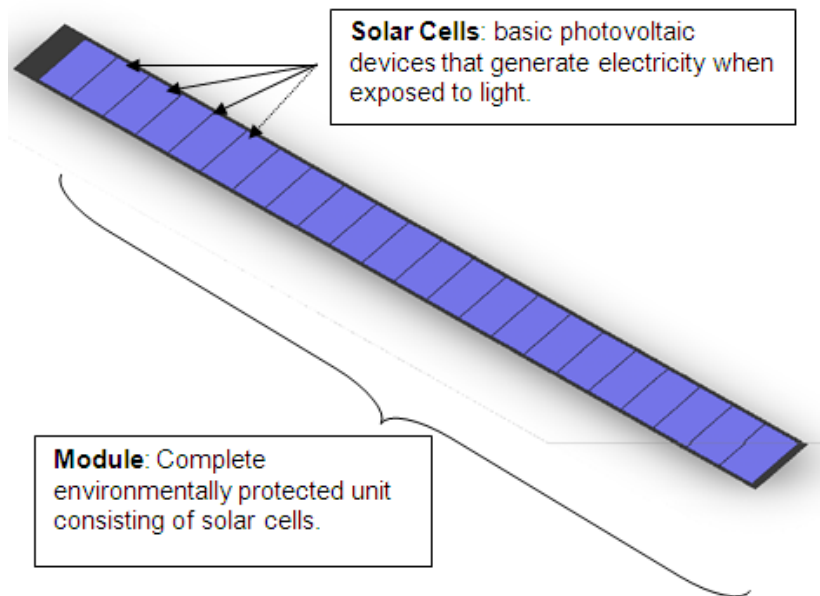

Figure 1 Photovoltaic Laminate PVL

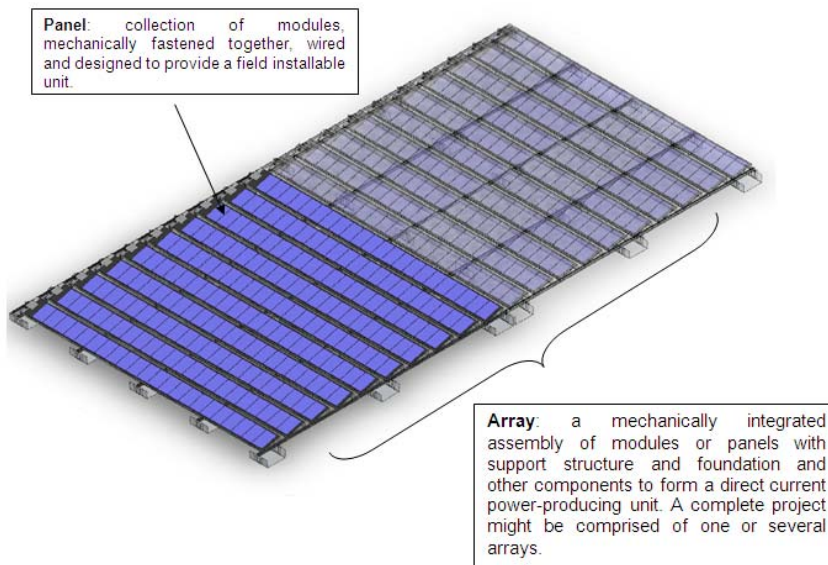
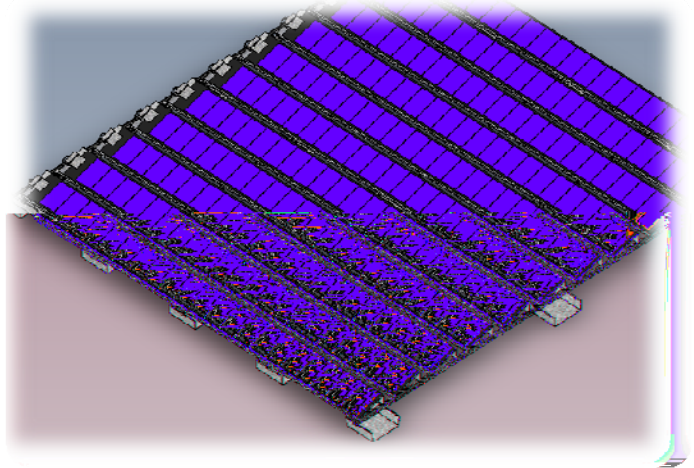

Figure 2 Panel and Array Construction

General Installation Notes

United Solar Ovonic LLC (*UNI-SOLAR*[®]), the leader in thin-film amorphous-silicon photovoltaic (PV) offers a new line of PV Laminates (PVL) application solutions, the *PowerTilt*. Unlike other photovoltaic technologies that use glass, *UNI-SOLAR* PVLs are flexible, lightweight and architecturally attractive. United Solar Ovonic PVLs are designed to provide many years of reliable and independent electric power. They perform at their maximum with the proper power system design, installation, use and maintenance. This manual is designed to assist owners, roofers, and electricians in the proper use and installation of the *PowerTilt* system for *UNI-SOLAR* PV Laminates.



The *UNI-SOLAR PowerTilt*, at 10.25¹ Kilograms/sq. Meter (2.1 psf), is ideal for low-load roofs; and its fixed 15 degree angle tilt will increase kWh/kW energy production performance. The integrated mounting frame of the *UNI-SOLAR PowerTilt* installs without the need for roof penetrations. Attachment mechanisms are available for gravel, PVC, TPO, EPDM, Modified Bitumen and standing seam metal roofs.

System design and component selections must comply with the National Electric Code (NEC) or Canadian Electrical Code and all state and local codes. *UNI-SOLAR* PVL holds class C fire rating for unlimited slope.

This installation manual encompasses the various stages of the *PowerTilt* assembly; from handling and applying the PVLs to the metal tilt pan, setting the metal tilt pans on supports, to adhering or ballasting the system. Installers may receive the system partially assembled with PVLs pre-adhered to the metal tilt pan. Installers are required to read the complete manual to understand all aspects of the installation of the *UNI-SOLAR PowerTilt* product. Special attention should be given to the areas specific to each installer.

Environmental Conditions ~ Storage, Handling and Bonding Requirements



Wear proper personal protection cut-resistant or leather gloves when handling this product.

1. *UNI-SOLAR* PV Laminates are shipped coiled in 1.22m x 1.22m x 43.18 cm (4'x4'x17") transport boxes.
2. *UNI-SOLAR* PV Laminates shipping boxes must be stacked no greater than three (3) boxes high. *UNI-SOLAR* PV Laminates should be stored at an ambient temperature between 50°F

¹¹ KSM of 12 Panel *PowerTilt* System excluding ballast

to 85°F (15°C to 30°C). The humidity conditions in the storage facility should not exceed 80%.

3. It is extremely important to have PV Laminates stored within the recommended temperature range prior to bonding.
4. *UNI-SOLAR* PV Laminates must be handled so as to not crease or bend the solar cells. Cells are interconnected with copper bus bars and these bus bars must not be stretched beyond their tolerances by coiling the laminate any tighter than 500 mm (20 inches) in diameter.
5. A tube made from cardboard, metal, or plastic should be used when handling the laminates. This will ensure that the minimum diameter is maintained during handling operation.
6. The area where the laminates are unpacked, handled, and bonded must be dry, clean, out of direct sunlight and free from excessive dust and sharp objects which could cause damage to the laminate surface.
7. Do not stand, walk or place any equipment on PV Laminates.
8. The temperature range for bonding United Solar Ovonic PV Laminates to a substrate is 50°F to 100°F (10°C to 40°C). It is required that the temperature of the laminate be within the specified range.

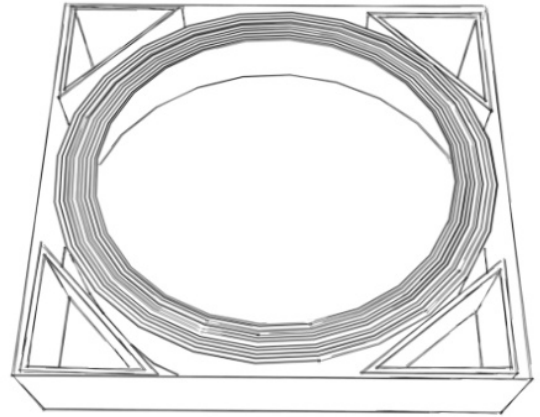

Figure 3 Gaylord of PVL

Do not handle PV Laminates by pulling on the Quick Connect Cables (Interconnect Wires)

Table 1 ELECTRICAL SPECIFICATIONS

Electrical Specifications									
PowerTilt Model Number ²	PT-29-*	PT-31-*	PT-33-*	PT-66-*	PT-68-*	PT-72-*	PT-128-*	PT-136-*	PT-144-*
Source PV Laminate Model Number	PVL-29	PVL-31	PVL-33	PVL-66	PVL-68	PVL-72	PVL-128	PVL-136	PVL-144
Rated Power Pmax [Watts]	29	31	33	66	68	72	128	136	144
Operating Voltage Vmp [Volts]	7.5	7.5	7.5	15	16.5	16.5	33.0	33.0	33.0
Operating Current Imp [Amps]	3.88	4.13	4.36	4.37	4.13	4.36	3.88	4.13	4.36
Open-Circuit Voltage Voc [Volts]	10.8	10.5	10.5	21.0	23.1	23.1	47.6	46.2	46.2
Short-Circuit Current Isc [Amps]	4.8	5.1	5.3	5.3	5.1	5.3	4.8	5.1	5.3
Series Fuse Rating [Amps]	10	10	10	10	10	10	10	10	10
Min. Blocking Diode	8	8	8	8	8	8	8	8	8

NOTES:

² Suffix -T or -B denotes Standard top terminated quick connects or Bottom terminated options (ex. PT-31-T or -B, top or bottom, respectively).

- During the first 8-10 weeks of operation, electrical output exceeds specified ratings. Power output may be higher by 15%, operating voltage may be higher by 11% and operating current may be higher by 4%.
- Electrical specifications tolerance for P_{max} is +/-5% and for other parameters is +/-10%. Electrical specifications are based on measurements performed at standard test conditions of 1000 W/m² irradiance, Air Mass 1.5, and cell temperature of 25°C (per ASTM E892) after long-term stabilization. Actual performance may vary up to 10% from rated power due to low temperature operation, spectral and other related effects.
- Under normal conditions a photovoltaic module may experience conditions that produce more current and/or voltage than reported at Standard Test Conditions. Accordingly, the values of I_{SC} and V_{OC} marked on UL Listed laminates should be multiplied by a factor of 1.25 when determining component voltage ratings, conductor capacities, fuse sizes and size of controls connected to the module output. Refer to Section 690-8 of the National Electric Code for an additional multiplying factor of 1.25 which may be applicable.
- Maximum system open-circuit voltage should not to exceed 600 VDC.
- These specifications subject to change without notice.

Application of top terminated PV Laminates (with quick connects) on metal tilt pan

Mechanical Tools

Cordless drill with torque settings
 Driver Bit Hex M8
 J-Roller
 Torque Wrench range 0-10 N·M (0-88.5 in·Lbs)
 Hellermann-Tyton (MK9)
 Cable Tension Tool

Materials Needed

Fine point permanent marker
 Isopropyl Alcohol
 Lint free rags
 3M 94 Primer
 Sonotube® or equal concrete form 20"
 Ruler
 3M #898 3/4" Wide Filament Tape or equivalent
 Appropriate Personal Protective Equipment (PPE)

Parts list

PVL
 Metal tilt pan
 Terminal Housing Cover
 Nut Member
 Thread Rolling Screw M5
 Cable Tie -4" Black Plastic
 Strain Relief Adhesive
 Mounting Pad

Use Proper Tools:

Always use proper tools which are in good, working condition during the installation of the Uni-Solar product. Using tools other than those listed could adversely affect the integrity of the product.

Top Terminated PVL with Quick Connects Application

PV Laminates Supplied Equipment

1. The PV Laminates are manufactured with the "quick connect" terminations contained on the end of the interconnect wires.
2. Mounting pads and zip ties used for module interconnect wire strain relief.
3. All shipments of PVL product can be accompanied by a factory supplied lamination roller (Contact *UNI-SOLAR* Sales office). This roller is called a J-roller because of its shape. Other rollers can be used but we recommend that the roller itself be made of a soft rubber material, ergonomically shaped for effective pressing and the handle of the roller attached to only one side of the roller axle.



Chemical Solvent Hazard: Follow all manufacture instructions or MSDS sheets for the safe use of Isopropyl Alcohol.

4. Cleaning solutions will need to be acquired for the metal tilt pans. Use Isopropyl Alcohol diluted to 90% alcohol / 10% water to improve cleaning.



Figure 4 Lamination Work Station and Metal Pan Wooden Template

5. Other tools required include a ruler (or template), a marker, and towels.
6. Installer will need to create a work station to hold the metal tilt pans rigid and flat during installation of PV Laminates. **Laminates will not bond completely if surface is not solid and secure.**



Lifting Hazard: To avoid personal injury, use proper lifting techniques and use two people to move assemblies, or the appropriate material handling equipment. Do not use the connection cables as handles.

The Power *Tilt* assemblies have two orientations; left and right handed based on location of interconnect wires.



Use Proper Installation Methods: Follow all instructions related to surface preparation. Failure to follow such instructions could cause the panels to detach from the roof surface after installation, resulting in personal injury and/or property damage



Figure 5 PowerTilt Orientation Front Profile

1. Determine the correct orientation of the PV Laminate on the metal tilt pan. Before adhering the PVLs to the metal tilt pans, verify the total number of each orientation needed and form a staging area for each orientation type. **KEEP TRACK OF MODULES MADE: ONCE PV LAMINATE HAS BEEN ADHERED TO METAL TILT PAN, IT CANNOT BE REMOVED.**



Chemical Solvent Hazard: Follow all manufacture instructions or MSDS sheets for the safe use of Isopropyl Alcohol.

2. Clean the metal tilt pan with isopropyl alcohol (90% Alcohol - 10% Water) where the double stick adhesive and the PV Laminate will be placed. If the pan is very dirty (material has been stored outside), the pan should be washed using a low-pressure water spray (i.e. garden hose) or power washer [11,000KPa (1600 PSI)] and a cleaning solution [59mL (¼ cup) Trisodium Phosphate, 118mL (½ cup) liquid detergent (optional) and 18L (5 gallons) water] and then rinsed before cleaning with alcohol solution.
3. The Metal Pans should be completely dry before installing PVLs.
4. PVL should be bonded while still on a flat and rigid surface with temperature between 50°F and 100°F (10°C and 40°C).

DO NOT HANDLE THE PV LAMINATES BY PULLING ON THE QUICK CONNECT CABLES (INTERCONNECT WIRES)

5. Wrap the innermost PV Laminate around the tube, and remove it from the box. The PV Laminate should be unrolled onto the cleaned metal tilt pan. Once unrolled, the brown protective paper can be removed.
6. Using a template, make a mark at 63.5 mm (2.5") from the top end of the metal tilt pan.
7. Align the long edge of the PV Laminates with top edge of the metal tilt pan (on high end) and verify location of PV Laminate on metal tilt pan.
8. Lift up the PV Laminate and double stick material about 300 mm (12") off of the metal



Figure 6 Installation of PVL

tilt pan, peel the protective liner (release) paper off of the double stick material approximately 150 mm (6") and fold it under. Adhere and secure the PV Laminate from top while carefully maintaining alignment. Ensure that the PV Laminate does not shift or move on the metal tilt pan during the application process. This is critical, as the PV Laminate's position will be fixed after the first 150 millimeters is bonded to the tilt pan.

9. Roll the PV Laminate up from the bottom until it meets the fixed portion of the PV Laminate and released paper.
10. Remove the remaining release paper while rolling the PV Laminate out slowly to remove all of the release liner across the adhesive.
11. **Press down on the PV Laminate with hand completely while rolling out to assure no air-bubbles are formed and caught under the PV Laminate.**

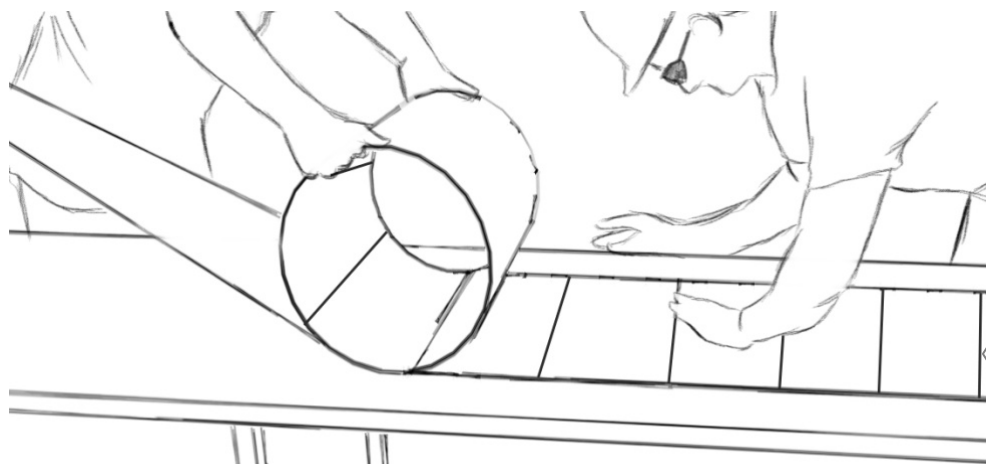

Figure 7 Installation of PVL-Adhering Laminate

Use your hand to push laminate roll to end while adhering. Side to side motion will help prevent air bubbles from forming.

12. After the PV Laminate has been applied completely to the metal tilt pan, use a roller to press the center of the laminate against the metal tilt pan. Then use a roller to press the PV Laminate onto the metal tilt pan, starting from the center of the laminate, and rolling out to the edges of the laminate.

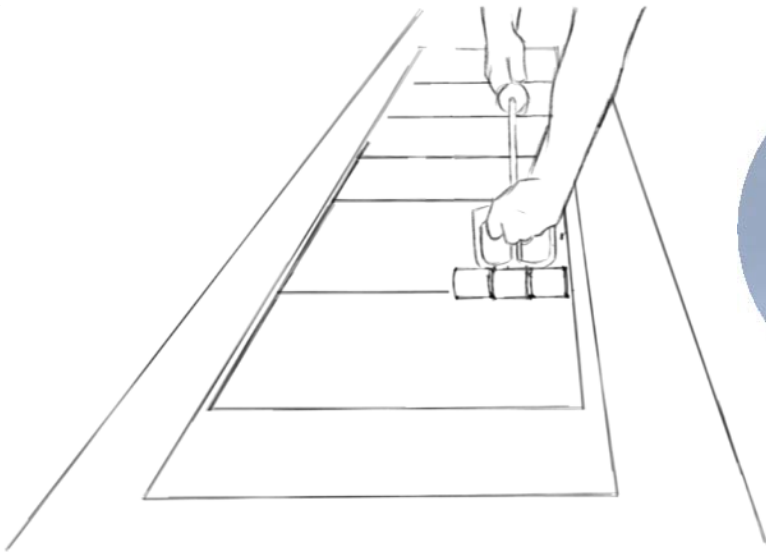

Figure 8 Installation of PVL-Securing Laminate



Figure 9 Use J-Roller to press out air bubbles

Strain Relief and Terminal housing Cover

The PV Laminates are supplied with factory installed module interconnect wires with MC Quick Connect terminals. These terminals are marked with a “+” plus sign or a “-” minus sign and will only fit into each other one way. It is required that additional strain relief for the wires is installed on the metal tilt pan.



Figure 10 MC Quick Connect Positive (+)

STRAIN RELIEF INSTALLATION

⚠ CAUTION

Chemical Solvent Hazard: Follow all manufacture instructions or MSDS sheets for the safe use of 3M 94 Primer.

1. Apply a thin layer of 3M 94 Primer or equivalent over the area where the cable mounts are to be secured. Allow the primer to flash off before installing the mounting pads.
2. Peel off release liner and place first cable mount into position. Position the mounting pad directly in line with the interconnect wire to allow the wire to lay straight. Align mounting pad corner with top edge of pan.
3. Remove the release liner on second cable mount and place into position directly in line with the other interconnect wire.
4. Thread two cable ties simultaneously into one mounting pad. Place one of the interconnect wires in center of mounting pad and tighten cable ties by hand.



Figure 11 Strain Relief

5. Using Hellermann-Tyton cable tension tool, tighten first the cable tie that wraps directly around the wire. Tighten to the highest setting recommended by the manufacturer.
6. Tighten the second wire tie.
7. Repeat the process for the second cable mount and ties.

TERMINAL HOUSING COVER INSTALLATION

1. Place the nut member on the bottom of the metal tilt pan, positioned so the plate is flat against the metal pan with the extruded holes facing down; and all the holes match with the holes of the metal tilt pan
2. Using the nut member grounding screw, secure the nut member to the bottom of the metal tilt pan with an M5 thread rolling screw, without fully tightening.
3. Align the terminal housing cover with the existing screw holes in the metal tilt pan and nut member. Be careful not to scratch the surface of the laminate.
4. Insert an M5 thread rolling screw into each of the four (4) holes of the terminal housing cover, torque all screws, including the nut member grounding screw, to 2.0 – 2.5 N·M (18-22 in·Lbs).
5. If the PowerTilt module is being assembled at a *UNI-SOLAR* facility, attach the PowerTilt product label by wrapping the label in half around the negative PV cable 150 mm (6”) from where it exits the terminal housing. If the PowerTilt module is being assembled on site, the PVL laminate will arrive with the label already attached.
6. Secure the interconnect wires before packing or assembling on the roof by wrapping both PV cables onto the top side of the PowerTilt module and securing with two pieces of 3M #898 filament tape (or equivalent), adhering the tape to the metal tilt pan.
7. After completing each PowerTilt module record serial number on the form provided [Appendix A: PowerTilt Bonding Path Resistance Check Sheet](#) and return to United Solar Ovonic, Quality Division³.

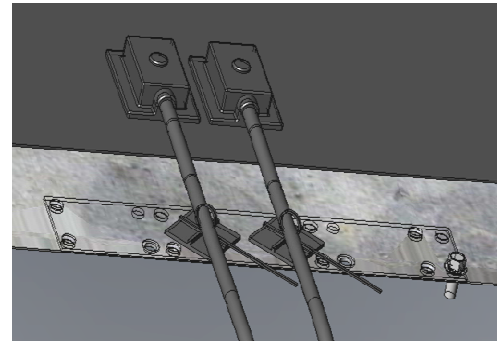

Figure 12 Nut Member

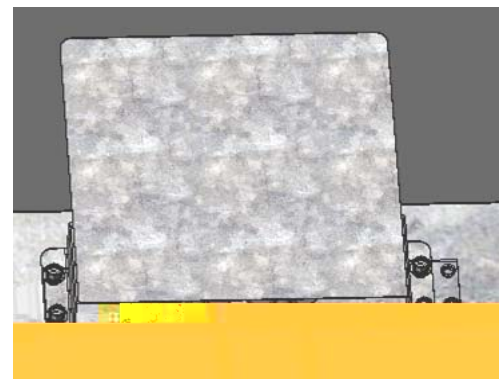

Figure 13 Terminal Housing Cover



Figure 14 PowerTilt Module-secured interconnect wires

DO NOT HANDLE THE PV LAMINATES BY PULLING ON THE QUICK CONNECT CABLES (INTERCONNECT WIRES)

³ 3800 Lapeer Road, Auburn Hills, Michigan 48326

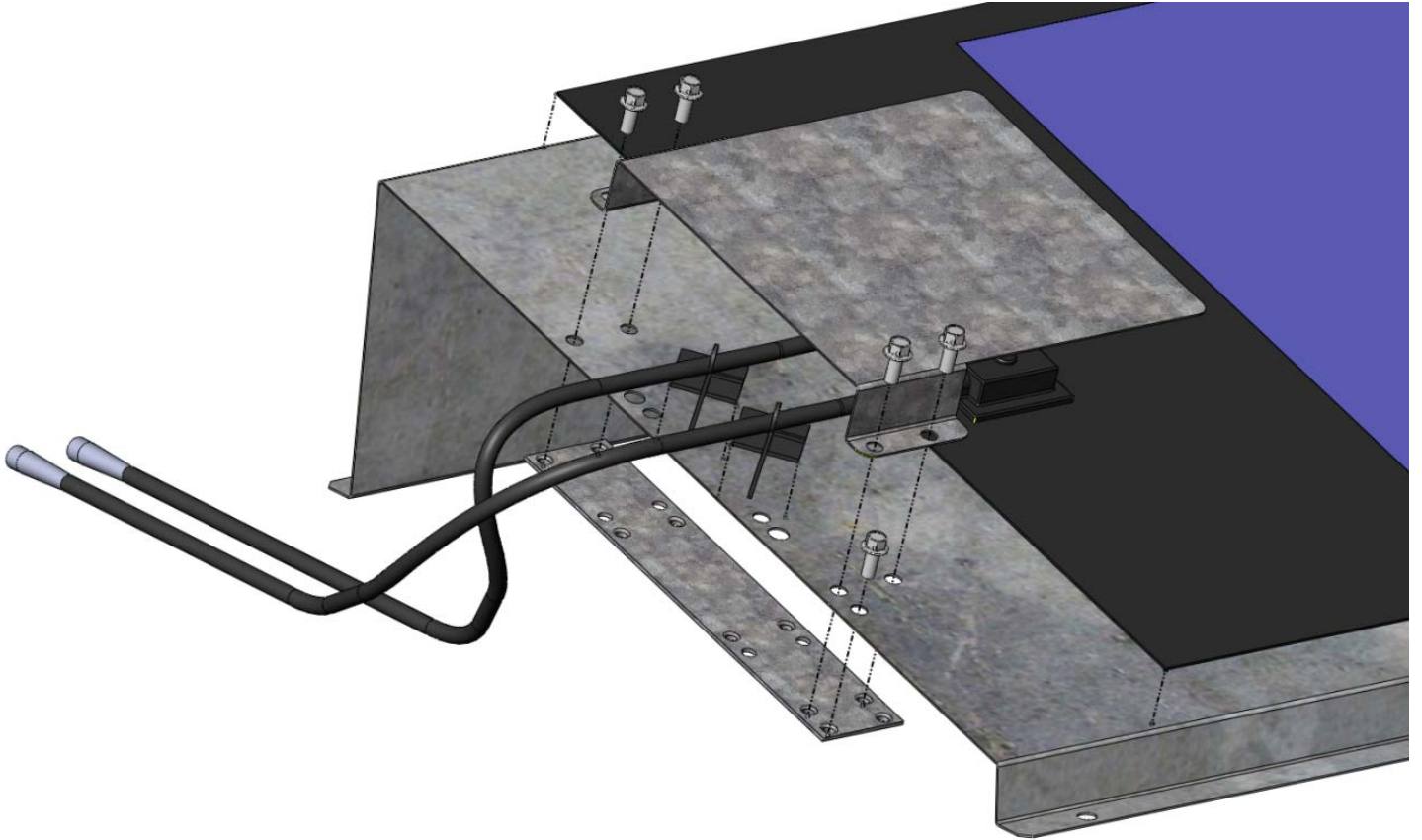

Figure 15 PowerTilt Module

Application of bottom terminated PV Laminates (with junction box) on metal tilt pan

Mechanical Tools
Phillips and flat Screwdriver
J-Roller

Materials Needed
Fine point permanent marker
Isopropyl Alcohol
Lint free rags
Sonotube® or equal concrete form 20"
Ruler
3M #898 ¾" Wide Filament Tape or equivalent
Dow RTV 739
Appropriate Personal Protective Equipment (PPE)

Parts list
PVL
Metal tilt pan
Un-solar J box with quick connects

Use Proper Tools:
Always use proper tools which are in good, working condition during the installation of the Uni-Solar product. Using tools other than those listed could adversely affect the integrity of the product

Bottom Mounted Junction Box PVL Application



Use Proper Installation Methods: Follow all instructions related to surface preparation. Failure to follow such instructions could cause the panels to detach from the roof surface after installation, resulting in personal injury and/or property damage.

The PowerTilt system is also available with bottom terminated PV Laminates. The metal tilt pans are pre-cut to accommodate bottom termination of PVL's wires.

1. Remove any protective film from the face of the metal tilt pan.



Chemical Solvent Hazard: Follow all manufacture instructions or MSDS sheets for the safe use of isopropyl alcohol .

2. Clean the metal tilt pan with isopropyl alcohol (90% Alcohol - 10% Water) where the double stick adhesive and the PV Laminate will be placed. If the pan is very dirty (material has been stored outside), the pan should be washed using a low-pressure water spray (i.e. garden hose) or power washer [11,000KPa (1600 PSI)] and a cleaning solution [59mL (¼ cup) Trisodium Phosphate, 118mL (½ cup) liquid detergent (optional) and 18L (5 gallons) water] and then rinsed before cleaning with alcohol solution.
3. The Metal Pans should be completely dry before installing PVLs.
4. PVL should be bonded while still on a flat and rigid surface with temperature between 50°F and 100°F (10°C and 40°C).
5. Determine the correct orientation of the PVL Laminates on the metal tilt pan. Before adhering the PVLs to the metal tilt pans, verify the total number of each orientation needed and form a staging area for each orientation type. **KEEP TRACK OF MODULES MADE: ONCE A PV LAMINATE HAS BEEN ADHERED TO THE METAL TILT PAN, IT CANNOT BE REMOVED.**
6. Make a mark at 64mm (2.5") from the top end of the metal tilt pan.
7. Insert plastic bushings into holes, one in each hole from the top side of the metal tilt pan.
8. Wrap the innermost PV Laminate around the tube, and remove it from the box. The PV Laminate should be unrolled onto the clean metal tilt pan. Once unrolled, remove brown protective paper.

DO NOT HANDLE THE PV LAMINATES BY PULLING ON THE QUICK CONNECT CABLES (INTERCONNECT WIRES)

9. The work surface should be flat and rigid. Make sure the end of the

metal tilt pan overhangs the working surface just past the plastic bushing in the bottom of the metal panel.

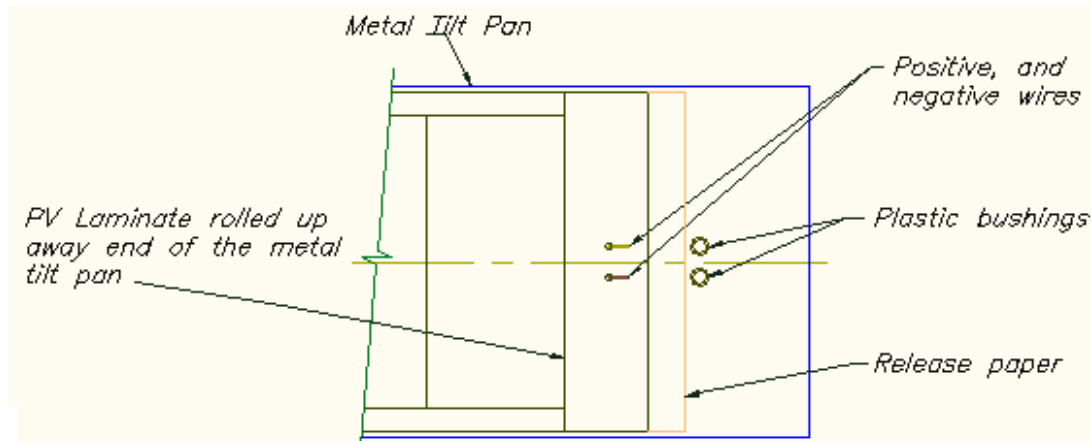

Figure 16 Laminite Positioning

10. Align the long edge of the PV Laminite with the top edge of the metal tilt pan (on high end) and verify location of laminite on metal tilt pan.
11. Check that the positive and negative wire and solder joint are centered in the plastic bushing. **IF IT IS NOT CENTERED, DO NOT ADHERE THE PV LAMINITE TO METAL TILT PAN.**
12. Lift up the PV Laminite and double stick assembly off the metal tilt pan just past the edge of the wires (about 51 mm (2") past the (2) two wires). Peel the release paper off of the double stick material approximately 150 mm (6") and fold it under.
13. Make sure the PV Laminite is aligned on the metal tilt pan and the PV Laminite does not move on the metal tilt pan during this process. This is critical as the laminite's position will be fixed after this first 150 millimeter is bonded to the metal tilt pan.
14. Carefully roll the PV Laminite back onto the metal tilt pan while placing the two (2) wires through the plastic bushings in the metal tilt pan. Stick the peeled end of the PV Laminite assembly onto the metal tilt pan.
15. Roll the PV Laminite up from the bottom until it meets the fixed portion of the laminite and released paper. Remove the remaining release paper while rolling the PV Laminite out slowly to remove all of the release liner across the adhesive.
16. Press down on PV Laminite completely while rolling out to assure no air-bubbles are formed

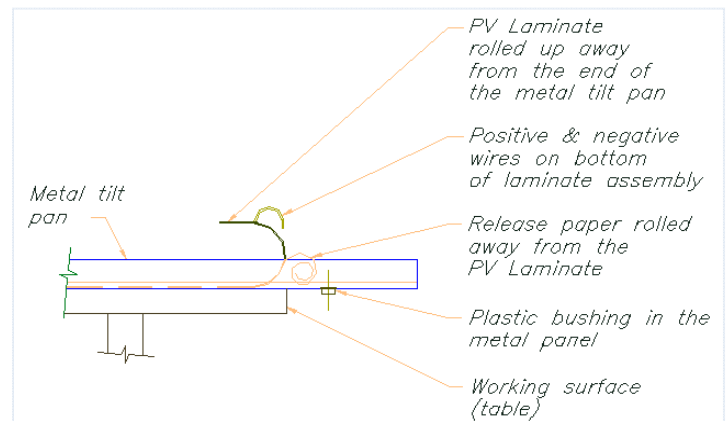

Figure 17 Side View

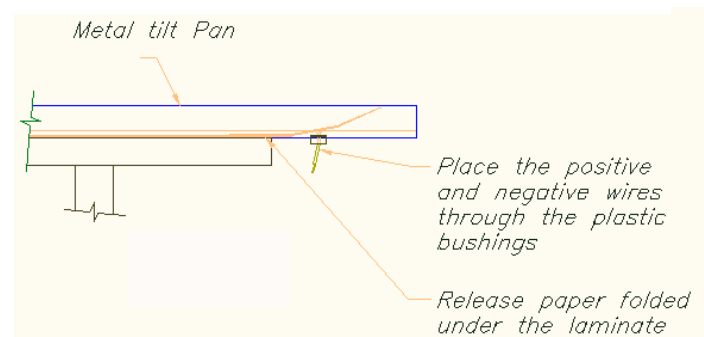

Figure 18 Installation of PVL

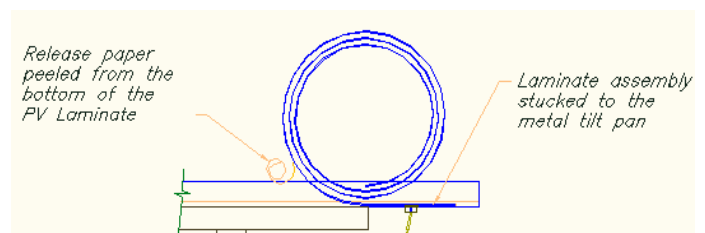

Figure 19 Installation of PVL-Aligning laminite

and caught under the laminate.

17. After the PV Laminate has been applied completely to the metal tilt pan, use a J-roller to press the center of the laminate against the metal tilt pan. Then use a roller to press the PV Laminate onto the metal tilt pan, starting from the center of the laminate, and rolling out to the edges of the laminate.

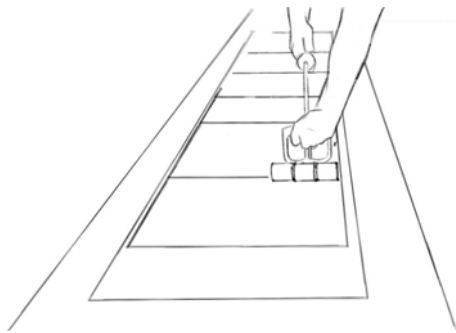

Figure 21 Installation of PVL – Securing laminates

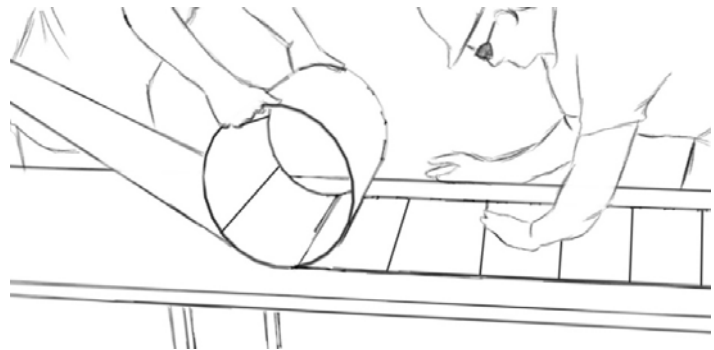

Figure 20 Installation of PVL –Adhering laminates

Installation of Bottom Mounted J-Box

1. Turn the metal tilt pan assembly so that the bottom side faces up, in order to place the J-Box on the metal tilt panel assembly.

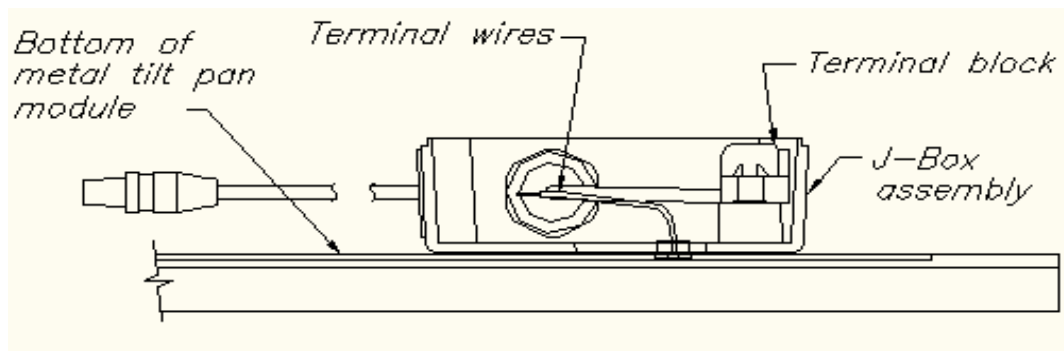

Figure 22 Side View of Junction Box

2. **NOTE:** Place a wood block 50.8 x 101.6 x 254 mm (2 x 4 x 10”) long beneath the metal tilt pan (between the PV Laminate and the working surface) in the area below the outline of the silicone sealant to help support the metal tilt pan when applying the J-Box assembly.



Lifting Hazard: To avoid personal injury, use proper lifting techniques and use two people to move assemblies, or the appropriate material handling equipment. Do not use the connection cables as handles.

3. Place the J-Box on the bottom of the metal tilt pan with the two (2) wires and plastic bushings placed through the opening on the bottom of the J-Box, see above section A-A.
4. Center the two (2) plastic bushings and termination wires on the bottom of the metal tilt pan in the center of the opening on the bottom of the J-Box, see View 25 and the Enlarged View, and make an outline of the J-Box on the metal tilt pan, see View 25.

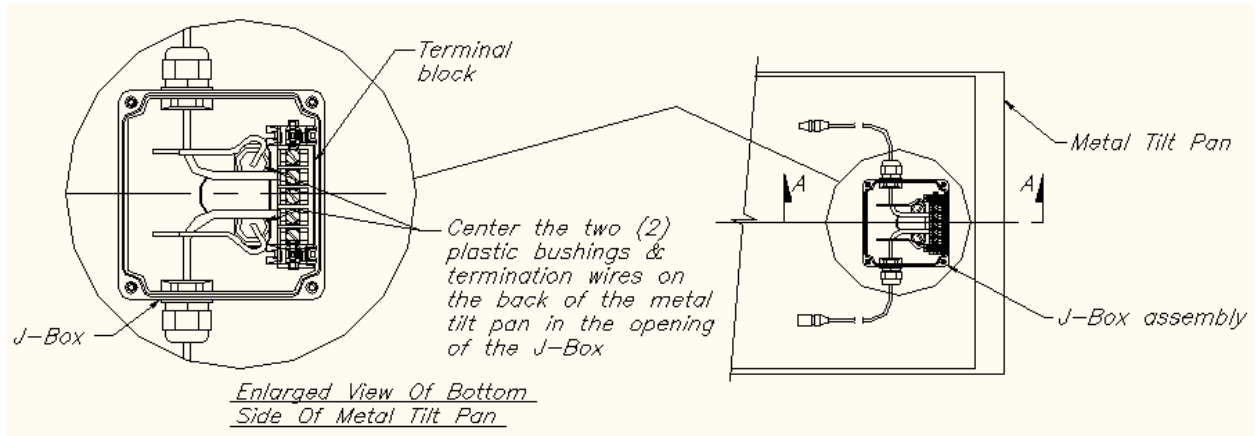

Figure 23 Junction Box Placement and attachment

5. After you outline of the J-Box on the bottom of the metal tilt pan, set the J-Box aside.
6. Apply Dow RTV 739 silicone sealant caulking just inside the marked position on the PV Laminate and metal tilt pan as shown.

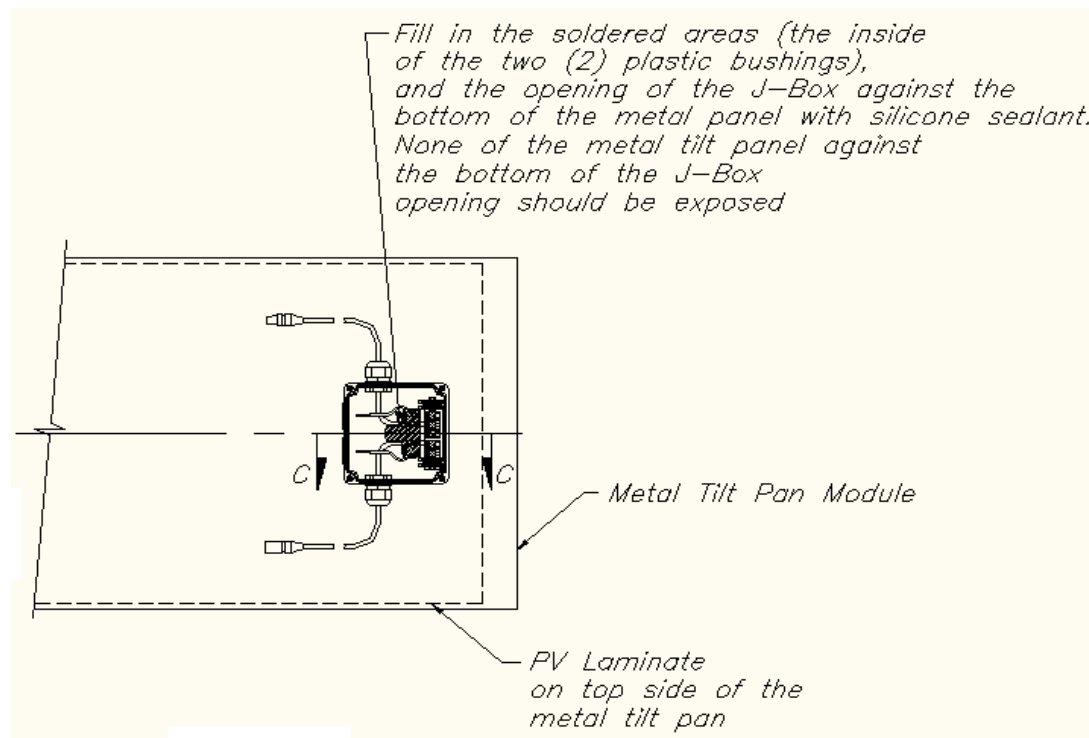

Figure 24 Securing Junction Box to Pan

7. Apply a steady and generous bead 6.35 mm by 6.35 mm (1/4" x 1/4") of silicone sealant to the inside perimeter of the outline of the J-box. Apply a small bead 6.35 mm x 3.2 mm (1/4" x 1/8") of silicone sealant on the inside perimeter of the rectangular marking around the two (2) terminal wires. Make sure that the sealant bead is continuous and uniform.
8. Make sure there is a piece of double sided tape on the bottom of the J-Box. Fill in the two openings on the bottom of the J-Box with silicone sealant. Remove the release paper from the double sided tape on the bottom of the J-Box.
9. Align the J-Box case on the silicone sealant on the metal tilt pan. Make sure the edges of the bottom of the J-Box are aligned properly with the silicone sealant on the metal tilt pan.
10. Make sure that the two terminal wires are properly aligned within the opening on the bottom of the J-Box.
11. Check to make sure the terminal wires are not trapped or pinched between the J-Box case and the bottom of the metal tilt pan.
12. Press the J-Box against the bottom of the metal tilt pan so that the double-sided tape on the bottom side of the J-Box sticks to the metal tilt pan.
13. Completely fill the opening in the bottom of the J-Box, including the inside and outside of the two (2) plastic bushings with silicone sealant, up to the inside edge of the opening. None of the metal should be exposed in the J-Box opening. Do not overfill the opening with sealant.

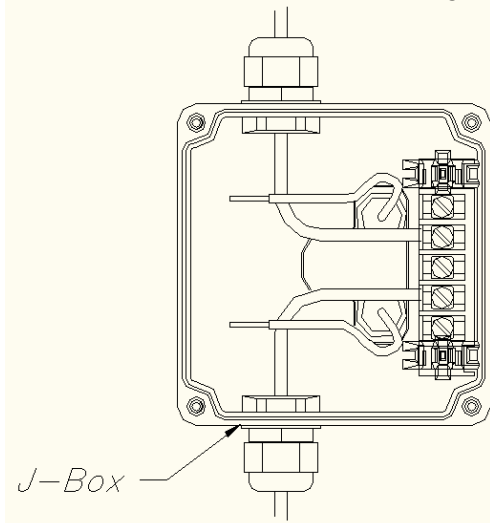

Figure 25 Junction Box Attachment

NOTE: YOU MUST ALLOW THE SILICONE SEALANT TO SET UP ("CURE") FOR AT LEAST EIGHT (8) HOURS BEFORE ATTACHING THE J-BOX COVERS.

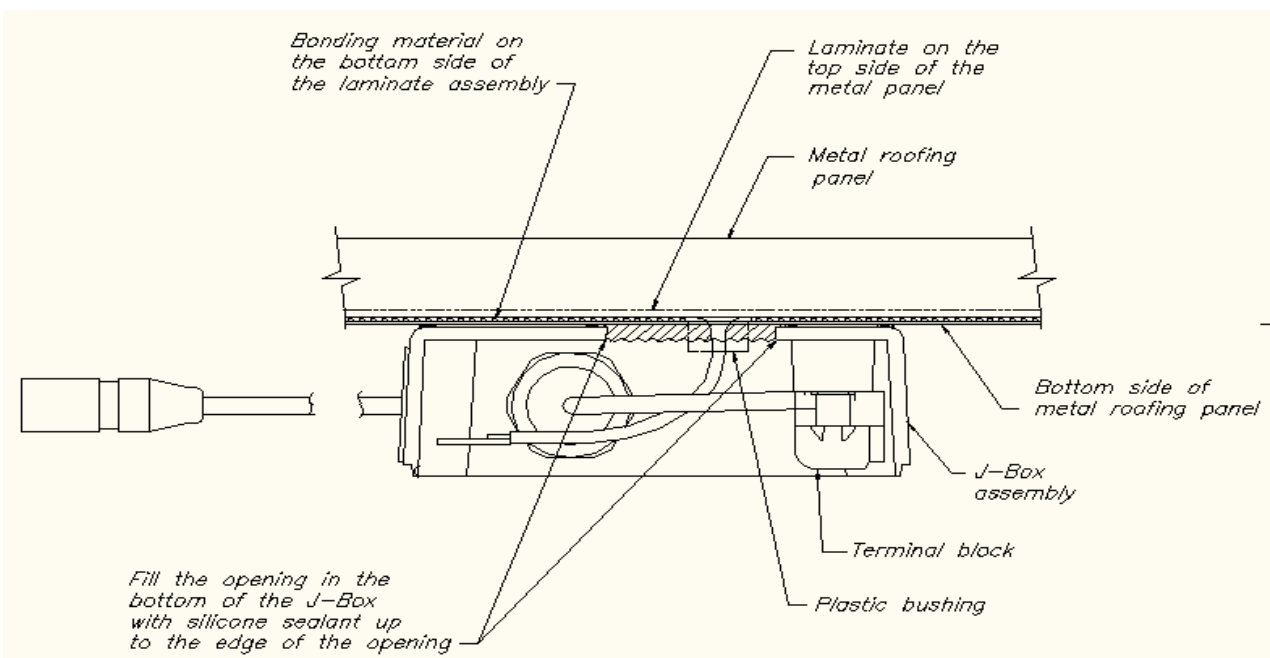

Figure 26 Junction Box Details

Complete Wiring of PV Laminate to terminal block. The junction box contains five terminal screws. The first screw on the left (as you look into the box) is the positive terminal. The last screw on the right (as you look into the box) is the negative. The second, third and fourth terminals are not wired to the active material in the module and can be used as extra spaces for wiring after installation of “jumpers” included with the hardware of every module.

1. Connect the PV module wires to the terminal block as per picture.
2. Place a J-Box lid on the top of the J-Box body.
3. Make sure that the direction of the UNI-SOLAR logo on the J-Box lid is properly placed with respect to the metal tilt pan.
4. Screw down the four screws of the four corners of the J-Box lid. The recommended torque range for the J-Box cover screws is 14 +/- 1 in-lb.

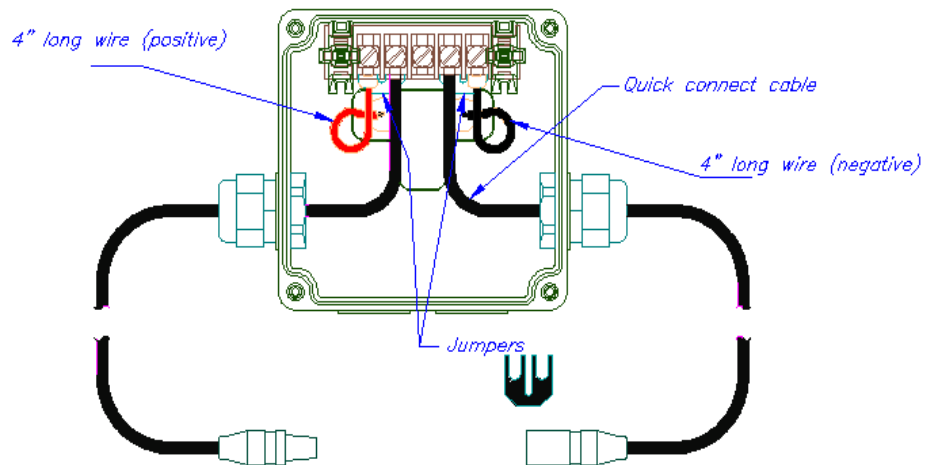

Figure 27 Junction Box Wiring Configuration

5. Using two (2) pieces of 3M #898 filament taper or equivalent, secure the wires to the metal tilt pan before packaging or assembling on the roof.
6. If the PowerTilt module is being assembled at a UNI-SOLAR facility, attach the PowerTilt product label by wrapping the label in half around the negative PV cable 150mm (6”) from where it exits the junction box. If the PowerTilt module is assembled on site, the PVL laminate will arrive with the label already attached to the interconnect wires exiting the junction box.
7. Secure the PV cable before packing or assembling on the roof by wrapping both PV cables onto the top side of the PowerTilt module and securing with two pieces of 3M #898 filament tape (or equivalent), adhering the tape to the metal tilt pan.
8. After completing each PowerTilt module record serial number on form provided in [Appendix A: PowerTilt Bonding Path Resistance Check Sheet](#) and return to United Solar Ovonic, Quality Division⁴.

Alternate Shipping Configuration ~ Assembled PowerTilt Module

Table 2 Shipping Crate Specifications

PowerTilt Crate Attributes – 30 Count per Crate	Specification
Weight	998 Kg (2200 Lbs.)
Length	5.715 m (18.75 ft)
Height	0.975 m (3.2 ft)
Depth	1.042 m (3.42 ft)
PowerTilt (Module)	25 Kg (55 Lbs) each ⁵

⁴ 3800 Lapeer Road, Auburn Hills, Michigan 48326

⁵ PT-144T

Storage and PowerTilt Modules Handling

1. *UNI-SOLAR PowerTilt* Modules are shipped in a 5.72m x 1.04m x 0.97 m (18.75'x3.2'x3.42') transport crates.
2. *UNI-SOLAR PowerTilt* Modules shipping crates must be stacked no greater than three (3) crates high during transport and/or while at the storage facility.
3. *UNI-SOLAR PowerTilt* Modules must be handled so as to not cut, bend or twist solar cells or metal tilt pan assembly.
4. Do not stand, walk or place any equipment on *PowerTilt* Modules.



Wear proper personal protection cut-resistant or leather gloves when handling this product.

Uncrating

1. Remove the cardboard protectors from wooden crate.
2. Drill out crate screws to remove cross braces.
PROTECT INTEGRITY AND WATER TIGHTNESS OF ROOFING SYSTEM. DO NOT ALLOW SCREWS AND NAILS FROM PACKAGING MATERIAL TO DAMAGE ROOFING SYSTEM.
3. Remove packaging material from *PowerTilt* module.
4. Remove metal pan assembly from crate using caution to protect the photovoltaic laminate along the top.
DO NOT PULL THE METAL TILT PAN ASSEMBLY BY THE INTERCONNECT WIRES.
5. Each metal pan weighs approximately 25 Kg (55 Lbs)⁶
6. Lift the *PowerTilt* module from the shipping crate by holding each end being careful not to scratch the surface of the PVL.
7. Remove metal tilt pans one at time using one person at each end to prevent damage to
8. *PowerTilt* pans.



Lifting Hazard: To avoid personal injury, use proper lifting techniques and use two people to move assemblies, or the appropriate material handling equipment. Do not use the connection cables as handles.



Figure 31 Crated PT Modules



Figure 28 PowerTilt Module Crate



Figure 29 Screws Securing Cross Braces

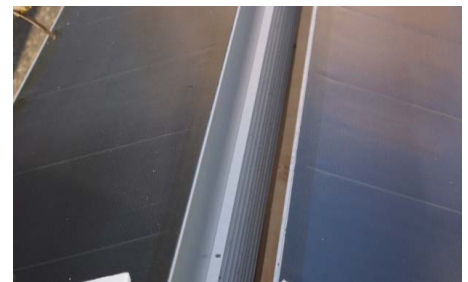
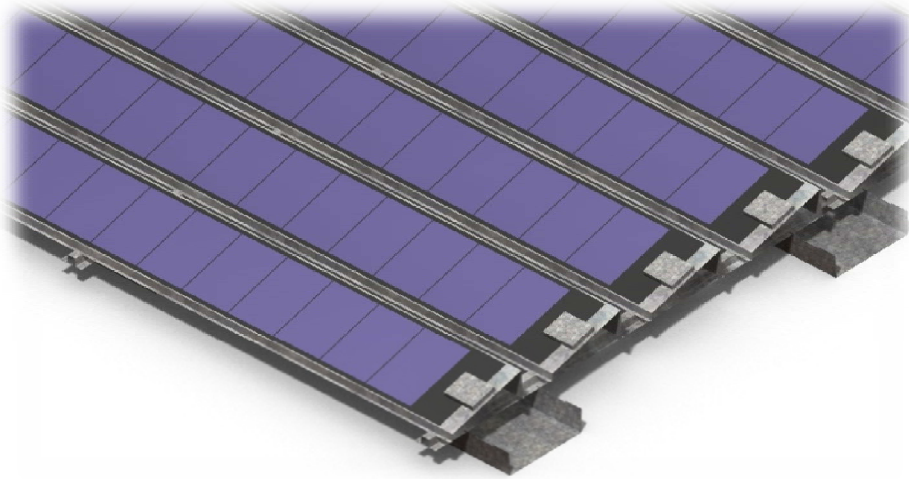

Figure 30 Supporting PowerTilt Modules

⁶ PT-144-T



PowerTilt-Mechanical Assembly

The PowerTilt assemblies have two orientations, left and right handed but each series string will be assembled with only one type of assembly. Left hand assemblies have the electrical cable exiting from the left side of the component, while right hand assemblies have the electrical cables exiting from the right side of the component.

Ballasting Qualification

The PowerTilt is a ballasted system. Follow the Ballasting information in [PowerTilt Array Ballasting Guidelines](#)

General Roof Application Installation Notes

1. The PowerTilt modules are to be mounted on a fire resistant roof covering
2. Local Building and Fire codes must be consulted prior to system design.
3. Contact appropriate local authorities prior to installation to determine if permits and inspections are required for your particular area.
4. Identify location on building for system layout within the roof system.
5. Do not install in areas where shadows are caused by nearby permanent, roof-mounted building equipment or walls.
6. Location should receive maximum allowable sunlight.
7. Wind uplift is at its maximum on roofing system near edges and corners.
8. Maintain required clearance from existing roof mounted equipment.

Table 3 PowerTilt Array Specifications

PowerTilt Key Attributes	Specification
Weight	10.2 Kg/m ² (2.1 Lbs/ft ²)
Wind Rating	144 KPH (90 mph)
Power Density	46 watts/m ² (4.3 watts/ft ²)
Snow loading	147 Kg/m ² (30Lbs/ft ²)

PRIOR TO THE ASSEMBLY OF THE ARRAYS, VERIFY THE FOLLOWING GENERAL INSTALLATION NOTES:

- ✓ Is there a planned layout or schematic for the Power *Tilt* System?
- ✓ Has an installation procedure been established? See [Appendix D: Suggested Installer Assembly Order](#)
 - Has the roof access for the installation crew and material been identified?
 - Has material staging areas on the roof been identified? Can these areas support estimated maximum loads during installation?
 - Is this maximum load within the building allowable range?
 - Has the process for material loading onto the roof been established?
- ✓ Are all arrays in the design layout at least six feet away from any building edge, wall or large structure?
- ✓ Are there any safety concerns regarding traffic of material and personnel on top of roof, i.e.: gas pipe line or spaces that need to be secured during the installation?
- ✓ Depending on the type of roof, extra material and labor may be required to complete installation.
 - Brick Pavers
 - Protective membrane sheets for single-ply membrane roofs.
- ✓ During installation, insure that materials are not left unattended on the roof un-ballasted or out of their crates to prevent parts from blowing off.
- ✓ Stage the material close to the array area to facility ease of assembly.



Lifting Hazard: To avoid personal injury, use proper lifting techniques and use two people to move assemblies, or the appropriate material handling equipment. Do not use the connection cables as handles.

Assembly of PowerTilt (10 Pans)

Mechanical Tools

- Cordless drill with torque settings
- Torque Wrench range 0-10 N·M (0-88.5 in·Lbs)
- Driver Bit Hex M10
- Tape measure
- Chalk Line Reel
- Clippers for Banding
- Crow Bar, Hammer for Unpacking Crates
- Protective Equipment (PPE)

Parts list

Q.	Description
15	BASE SUPPORT
30	RISER
100	M6 THREAD ROLLING SCREWS
60	M6 FLASH WASHER
1	WIRING TRAY
5	SUPPORT RAIL
10	POWER-TILT MODULE

Notes: These instructions build the array from right to left. The support rail rows will be laid out perpendicular to the tilt pans with the PVL. (For typical installations the modules will face south and the rows will run west to east). The rows should be laid out close to 53°. The support rails should also be parallel with each other.

Array Assembly

Alignment

The panel is built with a set of self-alignment features. The spacing of the rails is defined by pilot holes on the module. The spacing of the base supports is defined by the through holes on the flanges of the rails. The array is described in terms of rows and columns. The modules run in the direction of the rows and the support rails run in the direction of the columns. These instructions describe the installation of an array built upon Left-hand 10-module panels. The same principles also apply to Right-hand or Left-hand modules and to 5-module, 6-module and 10-module panels.



Use Proper Installation Methods: Follow all instructions related to surface preparation. Failure to follow such instructions could cause the panels to detach from the roof surface after installation, resulting in personal injury and/or property damage

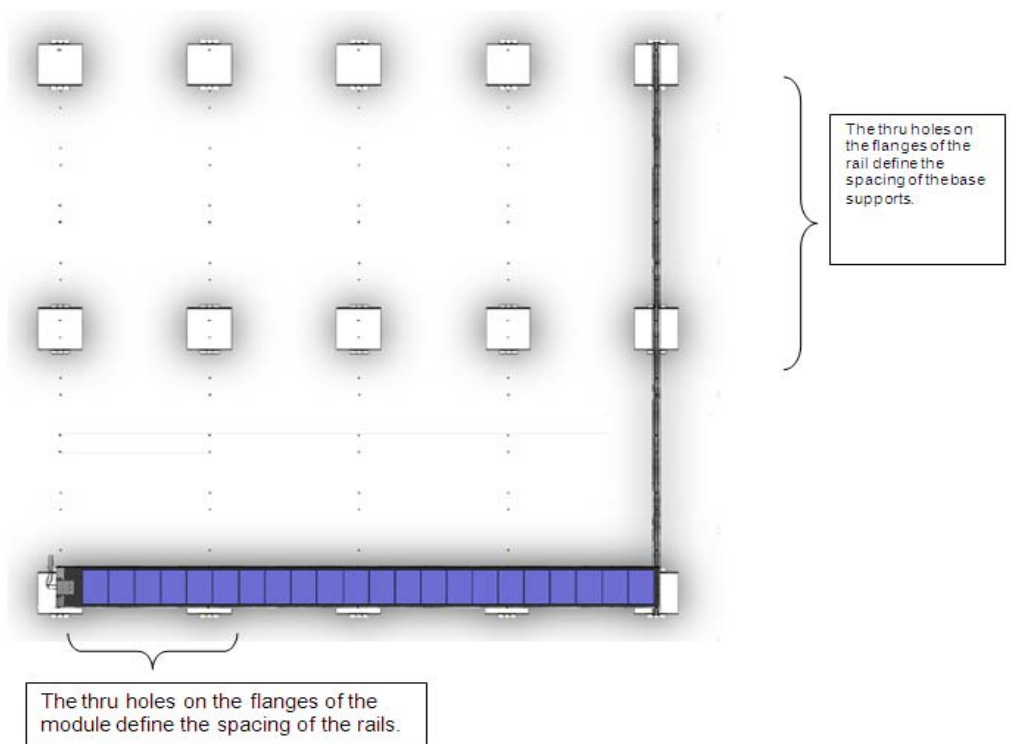

Figure 32 Array Alignment

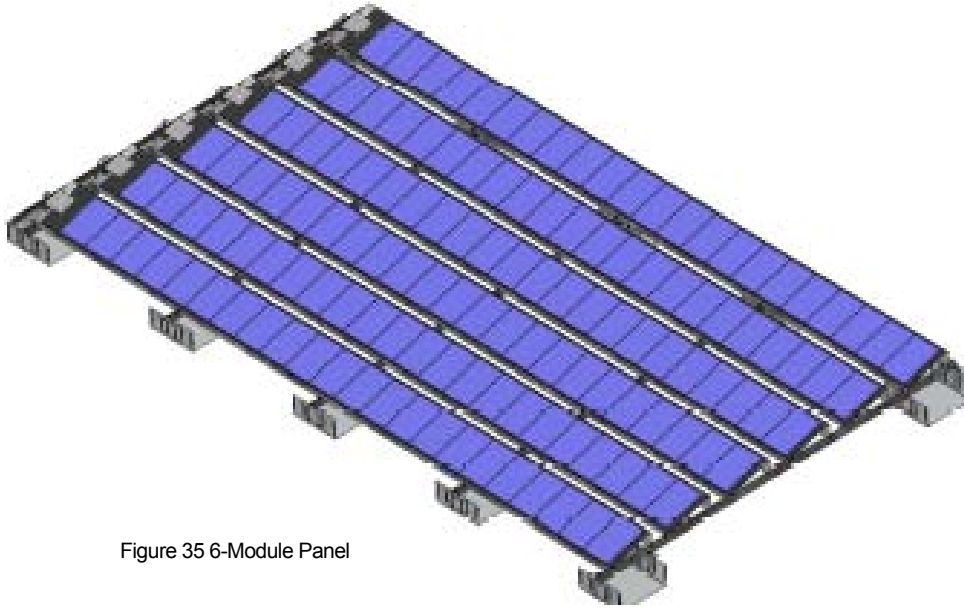

Figure 35 6-Module Panel

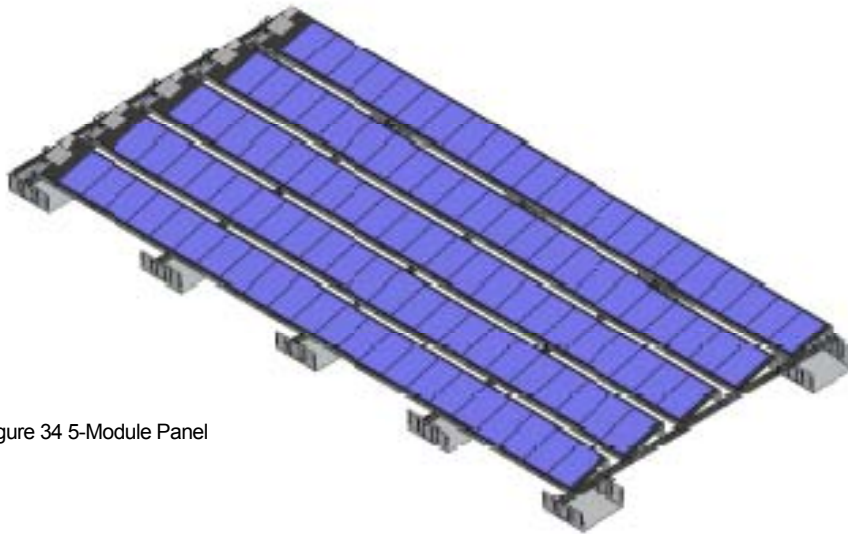

Figure 34 5-Module Panel

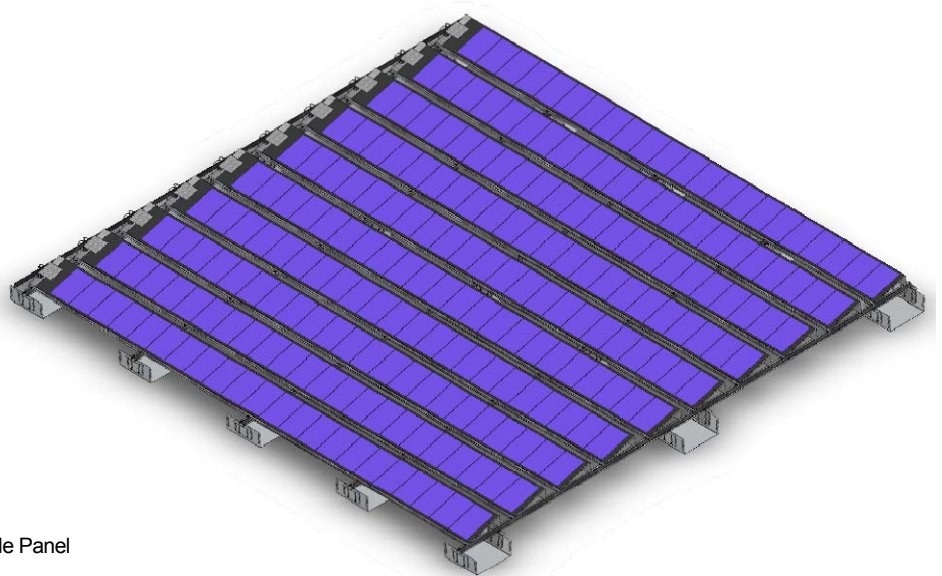

Figure 33 10-Module Panel

Construction

1. Identify location of the starting corner of the array and mark using chalk line reel.

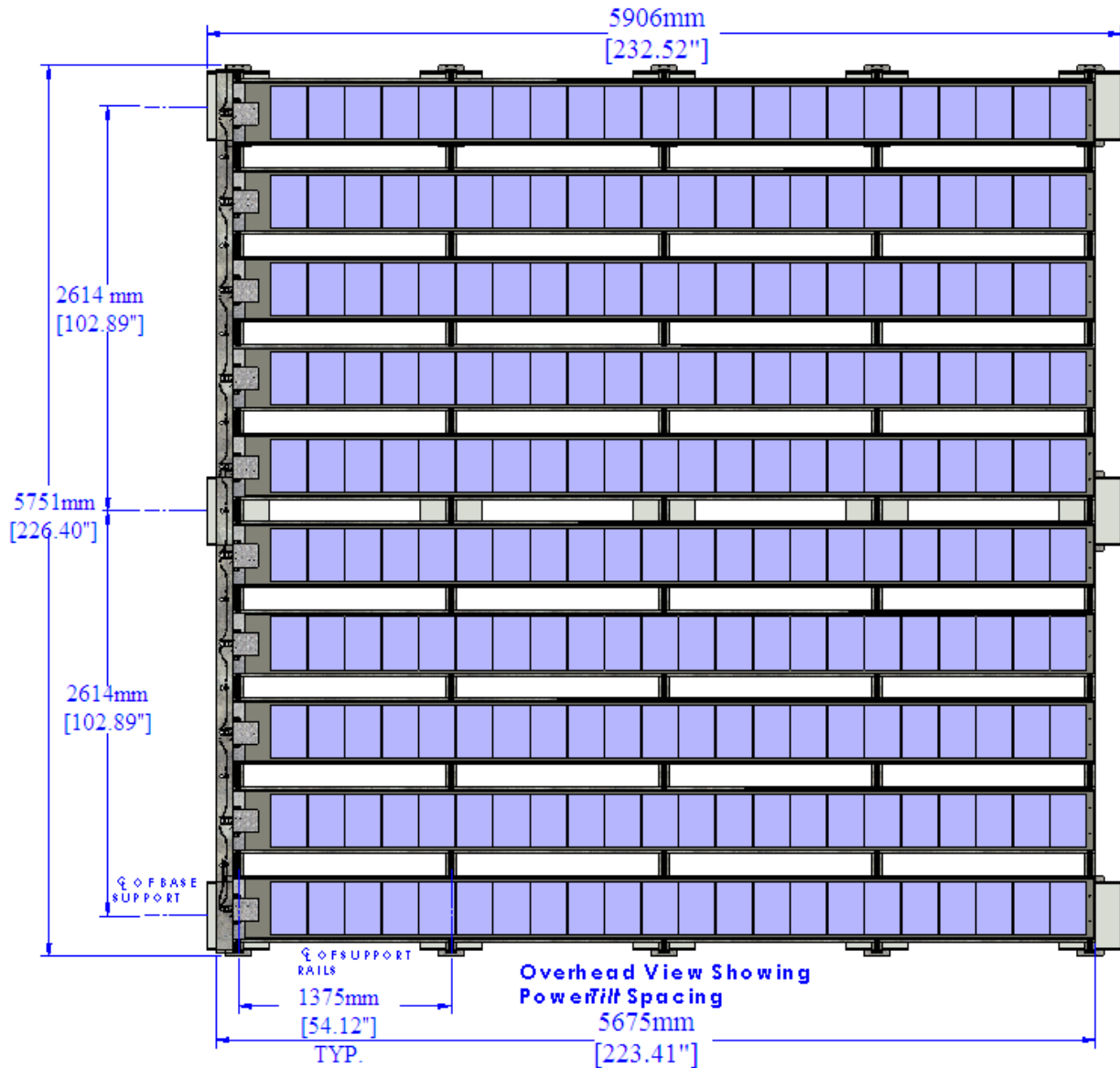

Figure 36 Completed Array Configuration

2. Remove all debris providing a flat surface where base supports will be placed. For ballasted roofs, remove the gravel and clean the areas with a broom. Place a piece of membrane beneath the base to protect the original roofing layer.⁷ The roofing membrane should cover enough area around the base to allow minor alignment during installation.

⁷ Preparation of existing roofing surface in preparation of United Solar PowerTilt system must be completed by roof manufacture approved representatives. United Solar Ovonix provides no warranty for water tightness of weather-proof system.



Figure 37 Base Support- Roof Preparation

3. The base support is comprised of a base and two risers that provide leveling capability to compensate for slope and irregularities on the roof surface. Before mounting the rail on top of the base support, verify that the risers are pre-assembled and free to move up and down along the base support.
4. If not fastened together attach the risers to the base utilizing the four (two per riser) M6 thread rolling screws with their corresponding flat washers. Do not tighten screws.

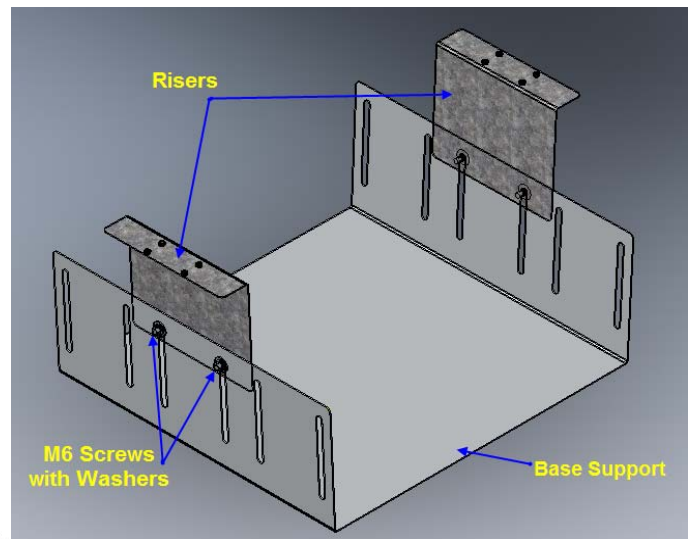

Figure 38 Pre-Assembled Base Supports with Riser

5. Position the fifteen (15) bases in three rows of five as shown.
6. Lay down five columns of rails with each column across the top of three base supports. Align each rail with the base support riser holes.
7. Mount the wire tray on top of support rail by aligning the holes on the tray with the holes on the support rail.

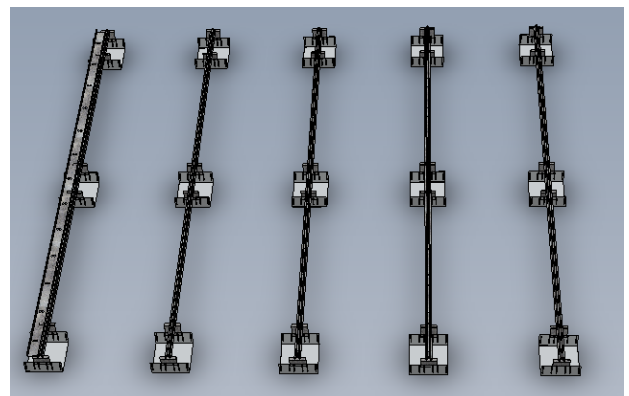
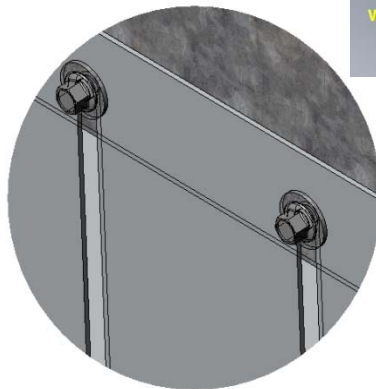

Figure 39 Base Support and Rail Alignment

8. Mount the wire tray across the base supports on the terminal housing cover side (same as interconnect wires).
9. Starting at the front of the array, using four M6 thread rolling screws, fasten the rail to both risers of the base support.
10. Snug the screws to zero or seating torque (below 2.0 Nm [18 in·lb]). Repeat this step for the base in the middle and end of the rail.
11. Place wire tray and support rail assembly on base supports. Align with holes in base support riser. Fasten the screws to zero or seating torque (below 2.0 Nm [18 in·lb]).
12. Using a click torque wrench, torque all M6 screws to 3.0 – 3.5 Nm (27 - 31 in·lb).
13. Align and fasten the remaining support rails with and bases in similar procedures.



Figure 40 Support Rail secured to risers of Base Support



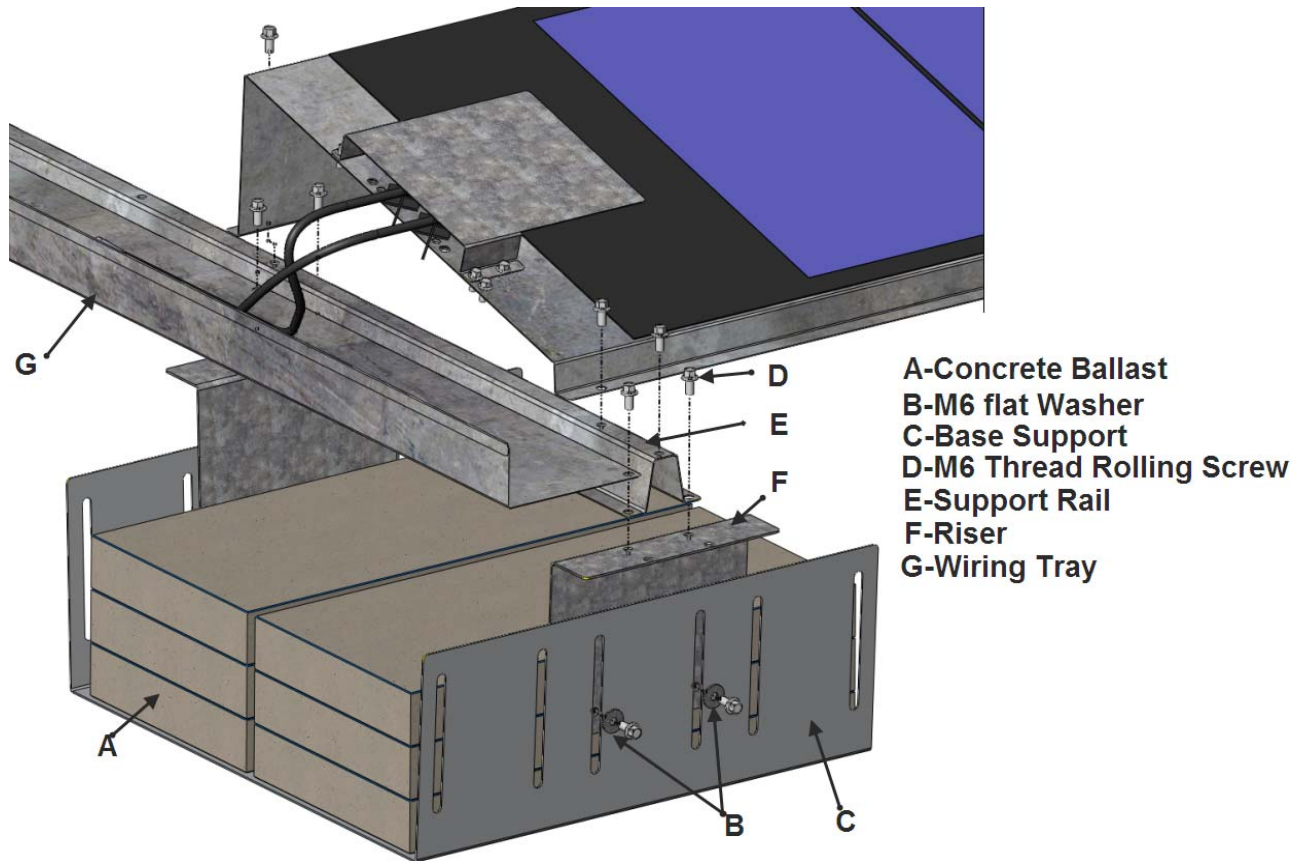

Figure 41 PowerTilt Module with Supporting Structure

14. Mount the second row module near front side of the panel, aligning the holes in the module with the holes in the rails. Using ten M6 thread rolling screws fasten the module to the rails. Snug the screws to zero or seating torque (below 2.0 Nm [18 in·lb]).
15. Mount the ninth module at the rear of the panel, following the previous step.
16. Once the rails and the second and ninth modules are mounted, tighten the M6 screws on the modules to final torque [3.0 to 3.5 Nm (27 - 31 in·lb)].

BALLASTING

17. Load ballast on base support according to ballasting design.
18. Verify that all base supports are sitting flat on the roof surface; plus the risers have self-adjusted to the height and tilt angle required by the rails.
19. Tighten the risers to the base supports [3.0 to 3.5 Nm (27 - 31 in·lb)] and verify torque with torque click wrench.
20. Mount the remaining modules to the rails and tighten as noted.

ADDING ADDITIONAL PANELS

21. Add additional panels by using the last row of base supports to mount the leading end of the next set of rails.
22. Repeat the same procedure to mount the wire trays.
23. Continue installing additional panels using the method described until the array is completed.

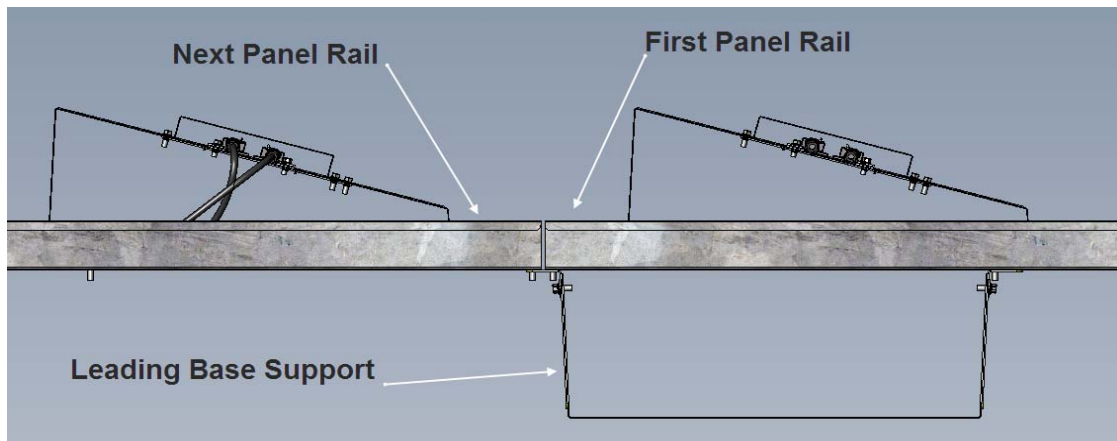

Figure 42 Array Attachment

24. At the end of the array place a grounding sticker next to the last rail extruded hole. See System Grounding Section.
25. When two or more arrays are merged into one, the base support will be assembled with two risers per side. If the terminal housing covers are facing each other, the wiring trays will be mounted between the modules as shown below.

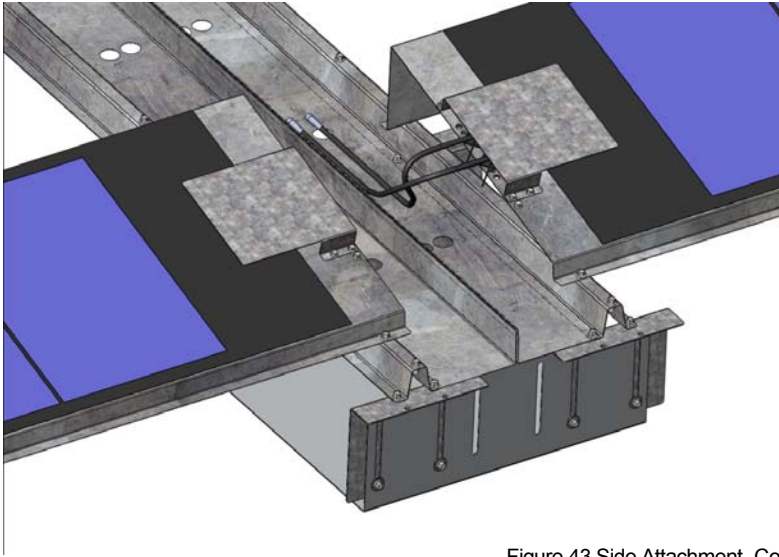

Figure 43 Side Attachment- Combined Wire way

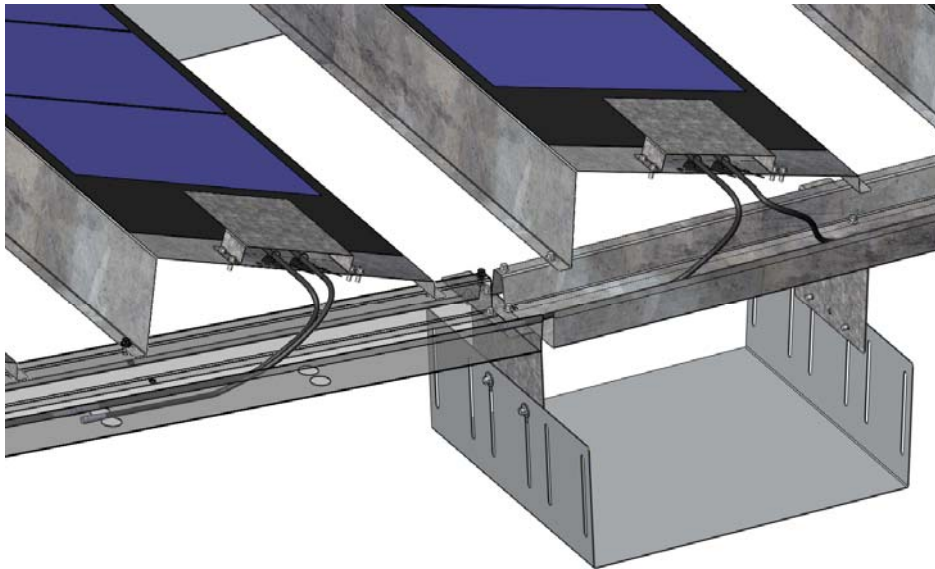

Figure 44 Extending Array

System Grounding

Mechanical Tools

Torque Wrench range 0-10 N·M (0-88.5 in·Lbs)
10 AWG crimp tool
Wire cutters
Appropriate Personal Protective Equipment (PPE)

Parts list

Grounding label
Flag ring Terminal
M6 thread rolling screw

Bonding Path Resistance Test

Equipment

AEMC Model 4630 Ground Tester
Hand held scanner

System Grounding

1. The PowerTilt is grounded at the end of an array⁸. The array ground is connected to system ground for common grounding point.
2. Place a grounding label near the last extruded hole on the end of the support rail that connects to the wire tray.
3. Attach a ground ring terminal to the end of the 10 AWG Copper Wire.
4. Using an M6 screw secure the grounding ring terminal to the extruded hole in the support rail and tighten to 3.0 -3.5 N·M (27 - 31 in·Lbs).
5. If an array extends beyond one panel, the support rails and the wire trays are bonded together through the riser of the Base Support.
6. Bare copper wire should not come in direct contact with galvalume wire tray or pans⁹. Insulated copper wire can be used in the wire tray.



Figure 45 Grounding Labels



Figure 46 Copper Grounding Wire

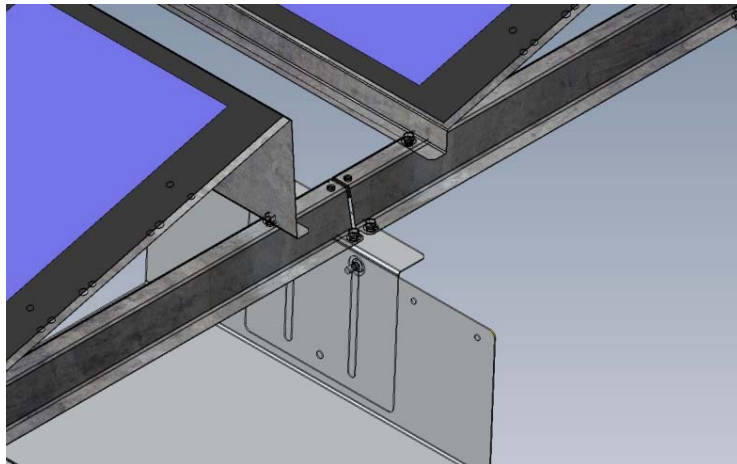

Figure 47 Arrays Bonded through Base Support Riser

⁸ Array: a mechanically integrated assembly of modules or panels with support structure, foundation and other components to form a direct current power-producing unit. (see definitions)

⁹ Lead and Copper are not compatible with Galvalume and should not make contact as will cause accelerated corrosion.

Bonding Path Resistance Test



Electrical Shock: Observe all electrical safety precautions to prevent electrical shock while installing laminates, performing wiring, testing, or maintenance of the PV

EQUIPMENT SET UP

1. Ensure that the green lead marked "x" and black lead marked "Xv" leads are NOT jumped together.
2. Attached the lead wires to their respective color on the ground test unit;
 - a. Red to "Z"
 - b. Blue to "Y"
 - c. Black to "Xv"
 - d. Green to "X"



Figure 48 Ground Resistance Tester

TESTING PROCEDURES

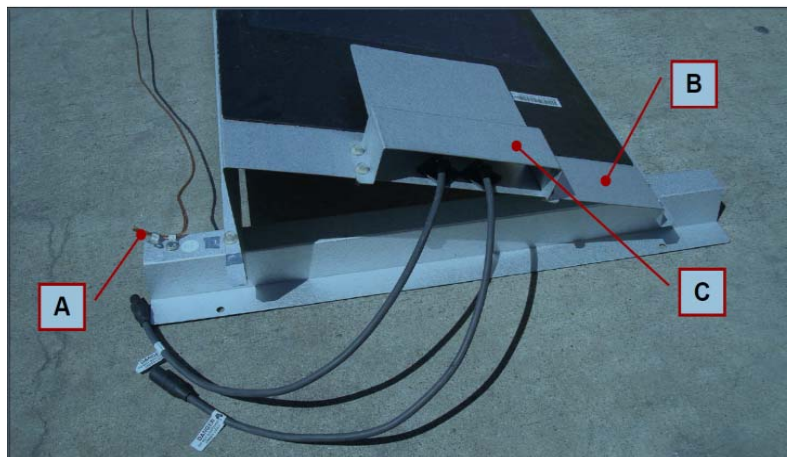

Figure 49 Ground Resistance Test Points

1. Clip the green and black leads to position A at the end of the array where system is grounded. *These leads remain in this location throughout testing of each PowerTilt Module in the array.*
2. Move along each PowerTilt module in the array and clip the red and blue leads to test point B on PowerTilt Module



Figure 50 Green and Black Clips attached to Point A

3. Verify system is safe to test. Risk of Electrical Shock.
4. Hold "Test" button down and let reading settle (~1 sec).
5. If resistance reading is less than 0.1 ohm then test point has passed.
6. Move along each PowerTilt module in the array and clip red and blue leads to test point C on PowerTilt Module.



Figure 51 Red and Blue Clips attached to Point B



Figure 52 Red and Blue Clips attached to Point C

Every PowerTilt Module in the array is tested at Point B and Point C against the array system grounding Point A.

7. Repeat same procedure from test point B for test point C:
 - a. Verify system is safe to test. Risk of Electrical Shock.
 - b. Hold "Test" button down and let reading settle (~1 sec).
8. If resistance reading is greater than 0.1 ohm then test point has failed
 - a. Re-check and fix any potential issues with the connectors and/or module.
 - b. Restart test.
9. If resistance reading is still greater than 0.1 ohm, then the module shall be considered failed.
 - a. Remove failed PowerTilt module from array.
 - b. Record the serial number and enter as removed.
10. If the module has pass both test points B and C, then record the serial number and enter as pass

Recording of data

1. Complete the PowerTilt Bonding Path Resistance Check Sheet provided in the appendix.
2. After measuring each module record the module serial number.
3. If the module has passed all the requirement of the testing procedure, place a check in the "PASS" field.
4. If the module failed any of the requirements of testing procedure, place a check in the "REMOVED" field.

Designing and installing a Solar Electric System

Requirements for Solar Electric System Installation

NOTICE

Approvals and Permits: To ensure a safe installation, contact the appropriate local authorities prior to installation to determine if permits and inspections are required in the jurisdiction of the installation. Installation shall be in accordance with NFPA 70, Article 690; Solar Photovoltaic Systems National Electric Code in the United States, or CSA 22.1 Safety Standard for Electrical Installations; Part 1 of the Canadian Electrical Code.

1. Permits
 - a. Building permits are applied for by contractor or installer.
 - b. Plans examiner reviews plans, grants approvals as required.
2. Installation
 - a. System is installed by a licensed contractor (manufacture certified installer) in a code-compliant manner, in accordance with jurisdictional requirements.
3. Inspections
 - a. Installation is inspected by the local building code official and approved.
4. Interconnection
 - a. Owner completes interconnection agreement with local utility, including requirements for system design and equipment, inspection certificates, insurance; disconnect provisions and other matters as required.

Wire Selection

- 90°C, wet rated conductors are necessary. Since PV Laminates interconnect wires are exposed use conductor type USE-2, or USE. If module interconnect wires and/or cables going from the to the combiner box are to be run inside of a wire chase, you can use RHW-2, THWN or XHHW-2 conductors.
- Temperature de-rated ampacity calculations for the DC side of your PV system should be based on 156% of the short-circuit current (Isc), and the de-rated ampacity must also be greater than the rating of the over-current device. Refer to the NEC Article 690.
- Although “Quick Connects” are used on PV Laminates universally, **“Quick Connects” are not designed to be used to disconnect PV Laminates while under load.** PV Laminates can be configured using series wiring, parallel wiring, or a combination of series and parallel wiring. Prior to entering the dwelling, the source circuits must be contained in metal conduit. Refer to NEC for guidance.

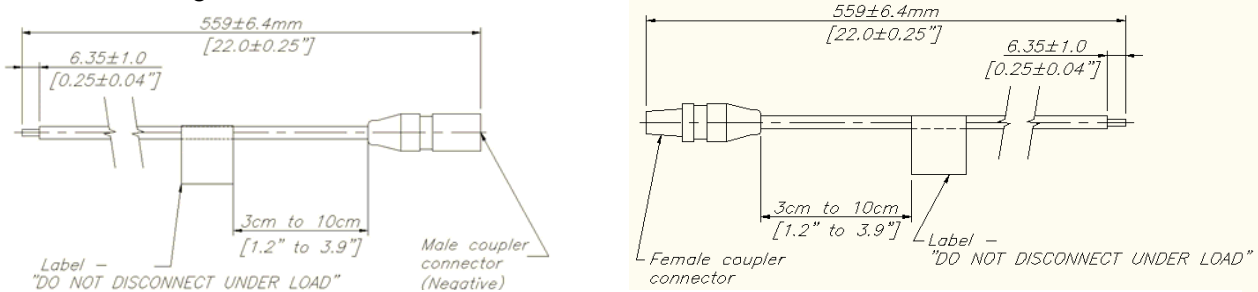

System Wiring



Electrical Shock: Observe all electrical safety precautions to prevent electrical shock while installing laminates, performing wiring, testing, or maintenance of the PV

- * *Run conduits into wire tray to avoid interconnect wires making contact with edges of metal tray. (as shown)*
- * *Cut module interconnects to appropriate length*
- * *Use the proper wire terminals*
- * *Crimp carefully (make a “lifetime” connection)*
- * *Seal junction box ingress and egress properly*
- * *Be careful with the junction box screws*
- * *Pay attention to your “drip loops”*
- * *Do series wiring first and parallel wiring second*
- * *Cover modules while you work during the day*

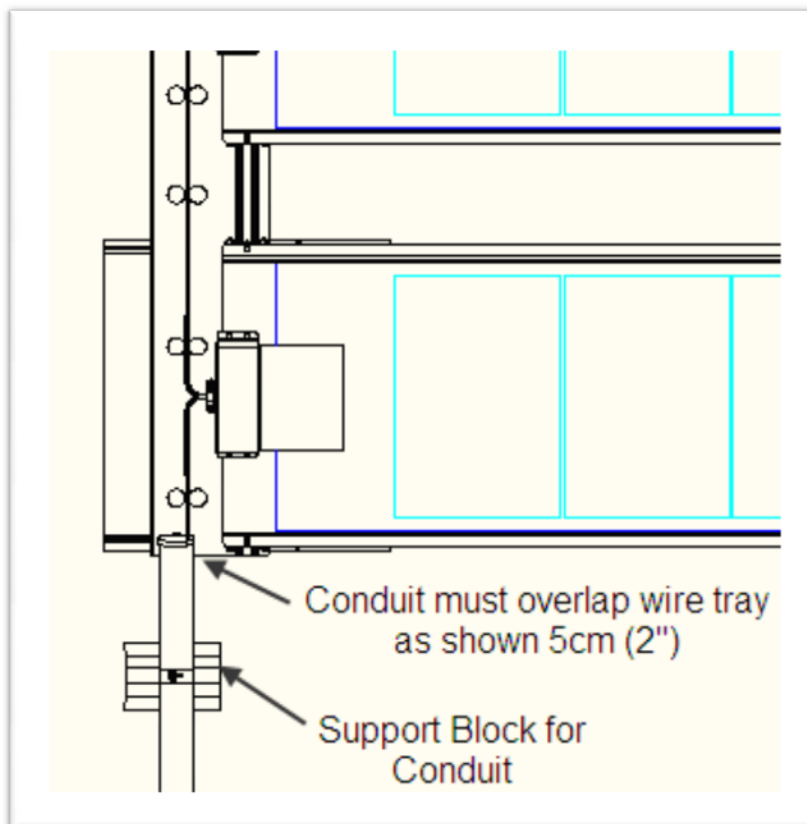

Figure 54 PowerTilt Wire Management

UNI-SOLAR PV products are the key components of a total solar electric system. There are many ways in which these systems can be designed and they include many other components, collectively known as the “balance of system” (BOS). This section is provided as background to assist owners and solar system installers in understanding the total system and the principles upon which it was designed. It is not intended to be a comprehensive guide to designing a solar system.

BOS (Balance of System) Components

BOS components vary depending upon the size and purpose of the power system. A solar power system used for water pumping may include only the PV Laminates, a combiner box and a pump. A small system used for lighting will include the laminates, a charge controller, batteries and some small DC lights. Larger solar energy systems may include an inverter, combiner boxes, disconnect switches, metering, and various fuses as well as the laminates, charge controller and batteries. Components common to most systems include the following:

- Combiner boxes - Outdoor rated (NEMA 3R or 4X) electrical boxes that will contain different combinations of compression terminals, module fuses and diodes. Combiner boxes provide a location for fuses and diodes and a place where wires from paralleled strings of laminates can be terminated. They come in three sizes: 4-input, 8-input, and 12-input models.
- Inverter - Used to convert DC power to AC power, and to control the power distribution in complex systems. Inverters can be configured to match the common AC supply in any country. Today, there are two main types of inverters; sine wave and modified sine wave. Sine wave inverters produce a cleaner waveform and the harmonic distortion is reduced. Modified sine waves are more efficient than sine-wave inverters and can be lower in cost. The most important factors to consider when using a grid connected inverter for power point tracking of a solar array is to match the array peak power with the inverter’s efficiency curves. Different inverters reach their peak efficiency at different levels of capacity. By matching the array to the inverter, you will be operating the inverter at its peak efficiency, thereby reducing power loss and total harmonic distortion. See inverter literature to find efficiency curves.

Selecting the “Right” System and Sizing

Selecting a solar system requires a detailed analysis of the site’s power needs, the amount of insolation (usable sunlight) in the area, the availability of other power sources (utility, other renewable energy sources, a generator) and cost. In utility serviced areas, an inquiry into the utility’s policy with respect to buying back excess power will be necessary. High summer peak power requirements and costs in an area may make selling all the produced power to the utility more economical than using the power on site, particularly if the site does not require much power during peak sunlight hours. However, the customer’s desire to use solar energy and/or desire for energy independence will also be determining factors in selecting and sizing a solar system.

UNI-SOLAR® PVLs are suitable for use in systems where system voltages do not exceed 600 volts. The PV Laminates can be wired in series, parallel or a combination of both to meet

system load requirements. When laminates are wired in series, the volts will add up while the amps remain the same. When laminates are wired in parallel, the amps will add up while the volts remain the same. By combining series and parallel wiring, any requirement can be met. **Do not use UNI-SOLAR® PV Laminates in systems having a maximum open circuit voltage greater than 600 volts DC.**

Elements of a Quality and Code-Compliant PV System Installation

1. System employs a well-engineered design and quality components;
2. System and equipment are properly sized to meet expected or required performance;
3. System uses listed, approved and appropriately rated equipment, and sunlight and weather resistant materials for outdoor application;
4. PV array is mounted in an accessible, unshaded location with proper solar orientation, and if needed, uses roof penetrations' weather sealing methods consistent with accepted roofing industry standards;
5. All equipment is properly labeled and safety hazards identified;
6. Installation complies with all applicable building and electrical codes and accepted utility interconnection practice;
7. System is inspected and approved by utility and code officials, owners/operators are trained on safety and operation.
8. PV system supplements on-site energy usage, electrical loads are supplied by either the PV system or utility or a combination of both, depending on the amount of PV generation and magnitude of the load.
9. PV array is directly connected to the inverter input, and inverter AC output is connected to the utility grid.
10. PV system operates in parallel and synchronously with the utility grid.

PV System Code Compliance: Common Problem Areas

1. Insecure structural attachment of PV arrays to rooftops and other structures (e.g., attachment of roof mounts directly to roof decking)
2. Inadequate weather sealing for roof penetrations
3. Unsafe wiring methods, insufficient conductor ampacity and insulation type
4. Lack of or improper placement or ratings of over current protection and disconnect devices
5. Unsafe installation, improper use and maintenance for balance of system equipment,
6. Use of unlisted equipment or improper application of listed equipment
7. Lack of or improper system grounding
8. Lack of or inadequate labeling on major system components and disconnect devices
9. Lack of or inadequate documentation on system design, and operating and maintenance requirements

System Operation and Maintenance



Electrical Shock: To avoid product damage, personal injury, or even possible death, carefully read, understand, and follow all the installation and safety instructions before attempting to install, wire, operate and perform maintenance on the laminates. Observe all electrical safety precautions to prevent electrical shock while installing laminates, performing wiring, testing, or maintenance of the PV

Safety Warnings for the Electrician / Technician:

- PV Modules are always energized during daylight hours unless they are covered with opaque material such as cardboard. Ensure the solar modules are completely covered with an opaque material before making wiring connections to reduce the risk of electric shock or sparks.
- Do not place equipment on the active area of the solar module.
- Avoid dropping any sharp, heavy objects on the solar modules.
- The panels are extremely slippery when wet; please take appropriate precautions before proceeding.
- Observe safe electrical practices at all times. Use insulated tools when wiring solar modules. Do not work on an energized array while standing in water.
- Observe proper polarity when connecting the solar modules into an electrical circuit. Reverse connection will damage the solar modules, may result in fire and/or will void the warranty.

Safety Warnings for the Roof Cleaner:

- Always wear rubber attire (i.e. gloves, boots...etc) that are **slip-resistant** and are rated for **electrical hazards** while cleaning the modules. The sole needs to be soft rubber to avoid scratching the laminates.
- Do not place equipment on the active area of the solar module.
- Avoid dropping any sharp, heavy objects on the solar modules to prevent cosmetic damage.
- Always keep the nozzle of a power washer at least 2 feet away from the surface at all times while cleaning.

Typical Solar System Operation

With today's inverter technology, a photovoltaic system will require very little day-to-day supervision from an operator. The PV modules and inverter will automatically start to produce energy as soon after the sun rises in the morning and will continue to produce energy until the sun sets at night. When the inverter detects that there is little or no energy coming from the solar modules, it will go into "Sleep Mode" until the morning. For example, contactors in the inverter will de-energize the transformer at night when the inverter is not operating. When the inverter detects power being generated by the solar modules (i.e. when the sun rises in the morning), the inverter will determine if the utility power is within specifications and if the utility power is stable, the inverter will automatically reconnect to the AC Service Panel (and utility

power lines) and start the cycle all over again. Please see the Inverter Operation and Maintenance Manual that came with your unit.

The inverter requires a connection to the utility power lines and is continuously monitoring the power quality at this connection. If the quality of the AC power fluctuates beyond standard tolerances or is cut completely, the inverter will sense this and automatically disconnect from the AC Service Panel and utility line. When the utility power is restored and the power stabilizes at its typical voltage and Hertz rate, the inverter will monitor this condition for approximately five minutes and then automatically re-connect to the AC Service Panel and to the utility power lines.

It is normal for a solar ("PV") array, after a certain period of time, to collect a film of dirt and dust over its active area. The amount of soiling on the array will be greater when the array is located near an incineration stack, construction site, airport, etc. Because this process is relatively slow, a drastic change in performance will rarely be seen.

Maintenance Scheduling

It is important to monitor the performance history of the photovoltaic system on a regular basis in order to develop appropriate maintenance schedules. Monitoring can be done using the standard display and functions on an inverter or with the installation of a more comprehensive data acquisition system.

To keep the solar electric system working at its peak performance throughout the year, it is important to schedule regular maintenance.

The most common maintenance task will be cleaning the dust and dirt that might have accumulated on the array. All electrical components need to be checked twice a year with the procedure below to ensure that the solar module strings are functioning properly and to ensure that no equipment is damaged. Typically, solar energy systems are checked once before the winter season (rainy/windy season) and then again after the winter (rainy) season.

Photovoltaic Array and Wire Runs

There are two main stages in the inspection of a photovoltaic array. A technician will first want to inspect the array for any damage and loose connections. The second step will be to clean the array using the cleaning procedure detailed at the end of this manual.

During the initial inspection, the technician will look for:

1. Debris and other source of shading that could partially block or damage the array.
2. Any instance where the laminate is not fully adhered.
3. Any scratches or cosmetic defects on the laminates
4. Any location where soiling might be worse than the rest of the array and will require more care.
5. Loose or damaged wires.
6. Wires that are not in conduit and check to see that they are bundled tightly together and are not being pinched or bound up in any way.
7. Damaged conduit or wire ways that could unnecessarily expose solar system conductors and connections.
8. Nesting by animals or insects.

Once all of these points have been inspected, the technician can proceed to wash the roof using the procedure at the end of the manual. **NOTE:** The roofing surface can be extremely slippery when wet. Please take the appropriate precautions (e.g. non slip soles, safety harnesses, etc.). If the technician feels at all uncomfortable getting up on the roof to clean the modules, the modules can be cleaned from the ground by squirting water above the array so that the water falls on the array like rain.

External and/or Internal DC Disconnects and Combiner Boxes

When it comes to the external disconnects and the Combiner Boxes, the technician has to ensure that the boxes are in good condition. During the inspection, the technician will want to make sure that:

1. All the labels are in place.
2. The disconnect switches are functioning properly.
3. The enclosures are free of debris, dirt, or nesting animals or insects.
4. All the connections and the screws are tight.
5. Corroded connections are cleaned and sprayed with anti-corrosion liquid.
6. Blown fuse are replaced.
7. Water is not penetrating the enclosure.

Once the inside of the enclosures are inspected, the technician can test the electrical performance of the array using a digital multimeter. This will ensure that all strings are functioning properly or will expose problems that would otherwise remain hidden. The electrical characteristics of the strings (i.e. open circuit voltage and short circuit current) should be very similar under the same environmental conditions. The technician will have to be careful when testing the performance during partly cloudy days. **NOTE:** The solar modules are wired at relatively high voltages (typically 300-400 VDC). This means that they will arc if connections are broken while the sun is up. It is best if connections are broken (e.g. the fuse holders in the Combiner Box are opened) during the night. Then each individual string can be tested for appropriate open circuit voltage and short circuit current during the next day. Voltage readings and current readings should be within 10% of each other on a cloudless day.

Inverter and Transformer

The maintenance of the inverter and the transformer should only be done by qualified personnel because of the lethal voltage that can still be present even when they are not operating. It is important that the inverter and transformer are isolated from all power sources by turning off both the DC and AC disconnects (and battery disconnect if applicable).

NOTE: It is recommended that the technician wait five (5) minutes after shutting down all power sources to the inverter before opening the cabinet. This will allow enough time for any capacitors inside the inverter to discharge.

Once the inverter has been safely shutdown, the technician will need to verify that:

1. All the labels are in place,
2. The enclosures are free of debris, dirt, or nesting animals or insects,
3. All the connections and the screws are tight,
4. Corroded connections are cleaned and sprayed with anti-corrosion liquid,
5. Blown fuses are replaced,
6. There is nothing resting or sitting on the inverter and transformer enclosures,

7. Water is not penetrating inside the enclosures, and
8. The inverter manual and warranty statement are inside the unit or nearby.

After the inverter is re-energized, the technician will verify that:

1. The inverter display panel is functioning properly, and
2. The ventilation or cooling system is functioning efficiently and adequate clearance around the heat sink or around ventilation screens has been maintained per the manufacturer's specifications.

AC Disconnect

With the AC disconnect, the technician has to ensure that the boxes are in good condition. During the inspection, the technician will want to make sure that:

1. All the labels are in place,
2. The disconnect switches are functioning properly,
3. The enclosures are free of debris, dirt, or nesting animals or insects,
4. All the connections and the screws are tight,
5. Corroded connections are cleaned and sprayed with anti-corrosion liquid,
6. Blown fuse are replaced, and
7. Water is not penetrating the enclosure.

PV Array Cleaning Procedure

PV Array Cleaning Procedure on metal tilt pan

Mechanical Tools

1. Leaf Blower
2. Soft Brush that can be mounted to a broomstick.
3. Clean and dry cotton mop head mountable on a broomstick.
4. Fiberglass/plastic broomstick
5. Low pressure water tank or low pressure “power washer”.
6. Mild cleaning solution. (e.g. Orange type, Liquid laundry detergent)
7. Source of fresh water. (Garden hose)

Materials Needed

Slip resistant rubber boots.
Rubber gloves.
Appropriate Personal Protective Equipment (PPE)

Use Proper Tools:

Always use proper tools which are in good, working condition during the installation of the Uni-Solar product. Using tools other than those listed could adversely affect the integrity of the product

1. Survey the roof for any loose wires, damaged modules and tough stains that will require special attention.
2. While surveying, remove all larger debris that can be found on the roof surface.
3. Use the leaf blower to remove all smaller size debris that can still be found on the roof surface.
4. Use garden hose to get the entire module wet. Take special attention not to spray water on electrical wires.
5. Use a soft brush mounted on the broomstick to dislodge excess grime from the module.
6. If hard-to-remove stains are found, a low-pressure water tank can be used to concentrate the water spray on the stain. If you are using a power washer, you can create a solution of ½ cup liquid laundry detergent, ¼ cup Trisodium Phosphate (TSP, liquid or powder), and five gallons of warm water. Put the feed tube from the power washer in the bucket as you are spraying the roof. **DO NOT** use the pressurized water to scrub the stain off the module.
7. Use a soft brush to scrub any difficult stains until they are completely dislodged. Take special care not to scratch the surface of the module.
8. Rinse the module with the garden hose until cleaning agent and grime are completely removed. **NOTE:** Observe where the cleaning agent is flowing after it is off the modules. You may need to capture the discharged cleaning agents and remove them to some other place.
9. Use clean cotton mop to dry excess water.

*This is the end of this section. Page
intentionally left semi-blank.*

Appendix A: PowerTilt Bonding Path Resistance Check Sheet

PowerTilt Bonding Path Resistance Check Sheet			
Name: _____			
Date: _____			
Site: _____			
Comments: _____			
#	Serial Number	PASSED	REMOVED
1			
2			
3			
4			
5			
6			
7			
8			
9			
10			
11			
12			
13			
14			
15			
16			
17			
18			
19			
20			
Notes: _____			

Current Measurement ID

Calibration Due Date

Voltage Measurement Device ID

Calibration Due Date

Appendix B: PowerTilt Array Layout Typical

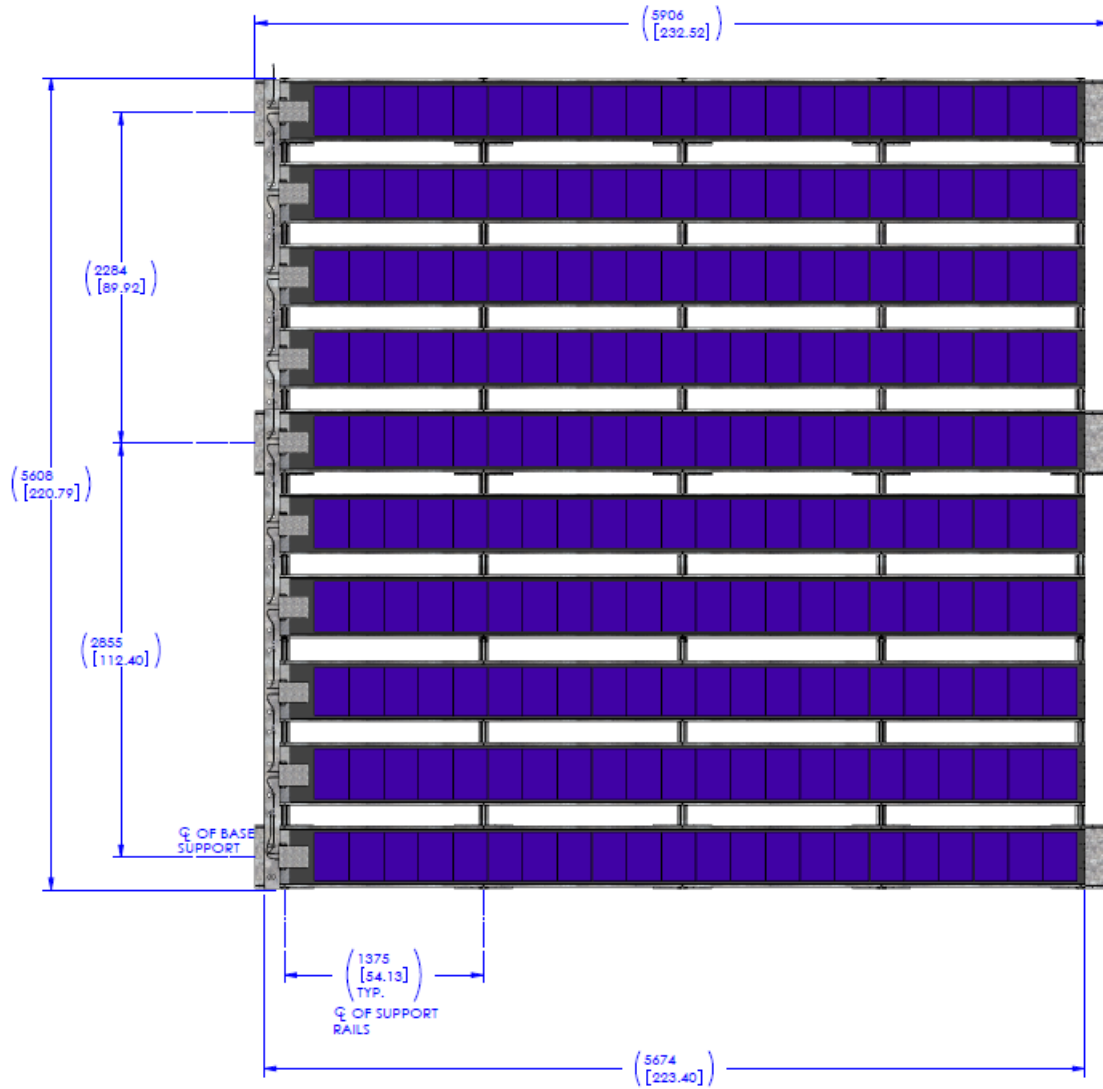

Appendix C: Suggested Material and Tools List

Use Proper Tools: Always use proper tools which are in good, working condition during the installation of the Uni-Solar product. Using tools other than those listed could adversely affect the integrity of the product.		
Mechanical Tools	Materials Needed	Parts list¹⁰
<ol style="list-style-type: none"> 1. Cordless drill with torque settings 2. Driver Bit Hex M8 3. J-Roller 4. Torque Wrench range 0-10 N·M (0-88.5 in·Lbs) 5. Hellermann-Tyton (MK9) Cable Tension Tool 6. Phillips and flat Screwdriver 7. J-Roller 8. Driver Bit Hex M10 9. Tape measure 10. Chalk Line Reel 11. 10 AWG crimp tool 12. Wire cutters 13. Clippers for Banding 14. Crow Bar, Hammer for Unpacking Crates 	<ol style="list-style-type: none"> 1. Fine point permanent marker 2. Isopropyl Alcohol 3. Lint free rags 4. 3M 94 Primer 5. Sonotube® or equal concrete form 20" 6. Ruler 7. 3M #898 ¾" Wide Filament Tape or equivalent 8. Dow RTV 739 9. Power Supply 2.0 A capacity 10. Voltmeter, millivolt resolution 11. One (1) pair of Kelvin clips. 12. Two (2) 10-meter extension leads. 13. Protective Gloves 14. Appropriate Personal Protective Equipment (PPE) 	<ol style="list-style-type: none"> 1. PVL 2. Metal tilt pan 3. Terminal Housing Cover 4. Nut Member 5. Thread Rolling Screw M5 6. Cable Tie -4" Black Plastic 7. Strain Relief Adhesive Mounting Pad 8. PVL 9. Metal tilt pan 10. Un-solar J box with quick connects 11. 15 Base Supports 12. 30 Riser 13. 100 M6 Thread rolling Screws 14. 60 M6 Flash Washer 15. 1 Wiring Tray 16. 5 Support Rail 17. 10 PowerTilt Module 18. Grounding label 19. Flag ring Terminal 20. M6 thread rolling screw

¹⁰ See Bill of Material for exact quantity and items

Appendix D: Suggested Installer Assembly Order¹¹

1. Assemble pans/risers
2. Place pans with padding underneath in cleared out areas
3. Assemble rails on risers. Screw down check level with extra rail and tighten to torque specs (riser screws and rail screws)
4. Screw down east-west rope on grounding holes at corners of 10 panel array. Do this in front and back of 10 panel array. Use tape marks to align inner rails.
5. One team of two will start work on ten panel array behind front set (steps 1-4); other team of two continues with steps 5-8.
6. Insert screws on panel (front and back), square and tighten each rail (to panel) to torque specs after squaring each rail. First panel only.
7. Repeat previous step on rear panel once it is put into place.
8. One team member will insert screws with power drill as panels are placed on rails. Second team member will tighten behind first to torque specs with hand tool.
9. Continue until 10 panel array is complete.
10. Start on new 10 panel array so only 2 team members are working on one section at a time.

¹¹ These notes are intended to provide installers additional information on practical application of process in this manual. The information is provided based on United Solar knowledge and experience and doesn't release contractor from following safe workmanship on installation of PowerTilt.

List of Figures/Illustrations

- FIGURE 1 PHOTOVOLTAIC LAMINATE PVL..... 3
- FIGURE 2 PANEL AND ARRAY CONSTRUCTION 3
- FIGURE 3 GAYLORD OF PVL 5
- FIGURE 4 LAMINATION WORK STATION AND METAL PAN WOODEN TEMPLATE..... 7
- FIGURE 5 POWERTILT ORIENTATION FRONT PROFILE..... 8
- FIGURE 6 INSTALLATION OF PVL..... 9
- FIGURE 7 INSTALLATION OF PVL-ADHERING LAMINATE 9
- FIGURE 8 INSTALLATION OF PVL-SECURING LAMINATE..... 10
- FIGURE 9 USE J-ROLLER TO PRESS OUT AIR BUBBLES 10
- FIGURE 10 MC QUICK CONNECT POSITIVE (+)..... 10
- FIGURE 11 STRAIN RELIEF 10
- FIGURE 12 NUT MEMBER 11
- FIGURE 13 TERMINAL HOUSING COVER..... 11
- FIGURE 14 POWERTILT MODULE-SECURED INTERCONNECT WIRES..... 11
- FIGURE 15 POWERTILT MODULE..... 12
- FIGURE 16 LAMINATE POSITIONING 14
- FIGURE 17 SIDE VIEW 14
- FIGURE 18 INSTALLATION OF PVL..... 14
- FIGURE 19 INSTALLATION OF PVL-ALIGNING LAMINATE 14
- FIGURE 20 INSTALLATION OF PVL –ADHERING LAMINATES..... 15
- FIGURE 21 INSTALLATION OF PVL – SECURING LAMINATES 15
- FIGURE 22 SIDE VIEW OF JUNCTION BOX..... 15
- FIGURE 23 JUNCTION BOX PLACEMENT AND ATTACHMENT 16
- FIGURE 24 SECURING JUNCTION BOX TO PAN 16
- FIGURE 25 JUNCTION BOX ATTACHMENT 17
- FIGURE 26 JUNCTION BOX DETAILS..... 17
- FIGURE 27 JUNCTION BOX WIRING CONFIGURATION..... 18
- FIGURE 28 POWERTILT MODULE CRATE 19
- FIGURE 29 SCREWS SECURING CROSS BRACES 19
- FIGURE 30 SUPPORTING POWERTILT MODULES..... 19
- FIGURE 31 CRATED PT MODULES 19
- FIGURE 32 ARRAY ALIGNMENT..... 22
- FIGURE 33 10-MODULE PANEL..... 23
- FIGURE 34 5-MODULE PANEL..... 23
- FIGURE 35 6-MODULE PANEL..... 23
- FIGURE 36 COMPLETED ARRAY CONFIGURATION..... 24
- FIGURE 37 BASE SUPPORT- ROOF PREPARATION..... 25
- FIGURE 38 PRE-ASSEMBLED BASE SUPPORTS WITH RISER..... 25
- FIGURE 39 BASE SUPPORT AND RAIL ALIGNMENT 25
- FIGURE 40 SUPPORT RAIL SECURED TO RISERS OF BASE SUPPORT 26
- FIGURE 41 POWERTILT MOODULE WITH SUPPORTING STRUCTURE 27
- FIGURE 42 ARRAY ATTACHMENT..... 28
- FIGURE 43 SIDE ATTACHMENT- COMBINED WIRE WAY..... 29
- FIGURE 44 EXTENDING ARRAY 29
- FIGURE 45 GROUNDING LABELS..... 30
- FIGURE 46 COPPER GROUNDING WIRE..... 30
- FIGURE 47 ARRAYS BONDED THROUGH BASE SUPPORT RISER..... 30
- FIGURE 48 GROUND RESISTANCE TESTER 31
- FIGURE 49 GROUND RESISTANCE TEST POINTS 31
- FIGURE 50 GREEN AND BLACK CLIPS ATTACHED TO POINT A..... 31

FIGURE 51 RED AND BLUE CLIPS ATTACHED TO POINT B.....32
 FIGURE 52 RED AND BLUE CLIPS ATTACHED TO POINT C.....32
 FIGURE 53 INTERCONNECT WIRES WITH MALE/FEMALE MC CONNECTORS33
 FIGURE 54 POWERTILT WIRE MANAGEMENT34

List of Tables

TABLE 1 ELECTRICAL SPECIFICATIONS5
 TABLE 2 SHIPPING CRATE SPECIFICATIONS18
 TABLE 3 POWERTILT ARRAY SPECIFICATIONS.....20

Index

ballast, 4, 28
 Ballasting Qualification., 28
 grounding
 System Ground, Ground, 11, 28, 30, 32, 36, 46
 Hellermann-Tyton cable tension tool, 11
 interconnect wires, 10, 33
 ISOPROPYL ALCOHOL, 8, 13
 J-roller, 7
 module
 PVL on Metal Tilt Pan, 6, 7, 10, 11, 18, 19, 22, 27, 32, 33, 35
 NEC
 National Electrical Code, 33
 release paper, 9, 14
 silicone sealant caulking, 16
 temperature, 8, 13
 template, 9, 13
 wire tray, 26

Global Headquarters
United Solar Ovonic LLC
2956 Waterview Drive
Rochester Hills, MI 48309
USA
Tel: +1.248.293.0440
Fax: +1. 248.844.1214
Toll Free (USA): +1.800.528.0617
info@uni-solar.com

European Headquarters
United Solar Ovonic Europe SAS
Tour Albert 1er
65, avenue de Colmar
92507 Rueil-Malmaison Cedex
France
Tel: +33.1.74.70.46.24
Fax: +33.1.41.39.00.22
franceinfo@uni-solar.com

German Office
United Solar Ovonic Europe GmbH
Robert-Koch-Straße 50
55129 Mainz
Germany
Tel: +49.6131.240.40.400
Fax: +49.6131.240.40.499
europa@uni-solar.com

Italian Office
United Solar Ovonic Europe GmbH
Via Monte Baldo, 4
37069 Villafranca (VR)
Italy
Tel: +39.045.8600982
Fax: +39.045.8617738
italyinfo@uni-solar.com

Spanish Office
United Solar Ovonic Europe GmbH
Sucursal Spain
C/ Llull 321-329
08019 Barcelona
Spain
Tel: +34 935530752
Fax: +34 935530753
spaininfo@uni-solar.com